



HME

®

HOSPITALITY & SPECIALTY
COMMUNICATIONS

ZOOM Nitro[®] **Vision AI**

INSTALLATION GUIDE

HM ELECTRONICS, INC.

2848 Whiptail Loop, Carlsbad, CA 92010 USA

Phone: 1-800-848-4468 Fax: 858-552-0172

Website: www.hme.com Email: support@hme.com

HME# PUB-00272

Rev E 03/18/26

IMPORTANT SAFETY INFORMATION, PLEASE READ FIRST

SAFETY NOTICE



CAUTION: Wear eye, hearing, and body protection when grinding, drilling, or working with tools. Follow the manufacturer's safety information and operational instructions for tools and materials.

Please be careful and comply with all safety protocols and warnings!

Failure to heed such precautions can cause property damage, injury, or death.

HYGIENE, HEALTH, AND SAFETY

Part of this installation requires working within a restaurant/store where food is prepared and customers dine. Please consult the restaurant/store manager, standard operating procedures, and any additional restaurant safety/advisory protocols available before beginning work within the restaurant/store. Follow the instructions and guidelines provided.

BATTERY DISPOSAL



HME cares about the environment. If this product uses batteries, please consult the laws and regulations within your municipality regarding the proper disposal of expired or damaged batteries.

TABLE OF CONTENTS

IMPORTANT SAFETY INFORMATION, PLEASE READ FIRST	III
Safety Notice	iii
Hygiene, Health, and Safety	iii
Battery Disposal	iii
INTRODUCTION	1
What's in the box.....	1
Tools, Equipment, & Materials Needed	1
SYSTEM OVERVIEW	2
Camera Placement in Drive-Thru Lanes and Mobile Spaces	2
General rules governing the placement of cameras:.....	3
SYSTEM WIRING DIAGRAM	4
INSTALLATION	4
Before you Begin	4
Running Cables	4
Install all System Components: Camera.....	5
Install all System Components: PoE Switch	9
Install all System Components: VPU.....	9
Connect all System Components.....	9
Verify or Adjust Camera View via ZOOM Nitro	10
ZOOM Nitro Setup, Drawing, and Configuring zones	12
Error Prompts when Configuring Polygons	18
Vision AI Detector Mapping on ZOOM Nitro.....	19
Completing the Installation	23
Photo Examples of Camera Views when Configured	24
HELP AND TROUBLESHOOTING	28
Troubleshooting	28
Network Requirements	31
Manual Configuration Using Computer and Camera.....	32
Verify the Camera Configuration and View.....	34
GLOSSARY OF TERMS	39
POE SWITCH TEMPLATE FOR WALL MOUNTING.....	43

INTRODUCTION

The purpose of this document is to explain the installation process for The HME ZOOM Nitro® Vision AI equipment with an emphasis on uniformity and ease.

WHAT'S IN THE BOX

- Video Processing Unit (hereafter VPU) with power adapter
- 5-port PoE Switch(s) (hereafter PoE switch) with power adapter
- Camera(s)
- Ethernet Cables (CAT6)
- Junction Box (used for cables and camera mount)

NOTE: The box contents and quantities may vary depending on sales order.

TOOLS, EQUIPMENT, & MATERIALS NEEDED

- Standard Hand tools:
 - Screwdrivers #1, 2, and 3 Phillips head
 - Screwdrivers 1/4", 3/16" and 5/16" Slotted/Flat-blade
 - Screwdrivers Philips and Flat-Blade "Tweaker" set
 - Pliers
 - Diagonal Cutters
 - Wire strippers
 - Utility knife
 - 25' Tape Measure
 - 8" Torpedo Level
 - Torx/Allen Wrench (this is included with the Camera hardware kit for adjusting camera angle and rotation)
- Cat6 cable tester
- Wire Tracer/Toner
- Hammer Drill 3/8" 18-cordless with spare battery or corded (recommended for masonry work)
- Masonry drill bit set (including 3/4" diameter 18" long masonry bit for wall penetration for cable)
- Fish sticks/fish tape "Green" sticks or routing/pulling cables
- Ladder (10' minimum or taller, as nominal camera installation height is 12 to 14 feet).
- Digital Camera (Smartphone camera will suffice)
- Cell Phone
- Laptop computer running either Windows 7 or later or Mac OS X version 10.7.5 (Lion) or later

Materials

- Cable ties, including screw-mount/mounting-hole cable ties.
- Hardware/Fastener Assortment.
- Electrical tape, twist caps, sleeving, or conduit.
- Waterproof sealant or equivalent (for sealing the entry point of the Ethernet cable into the building).

Safety Equipment

- Safety Glasses

SYSTEM OVERVIEW

Install, test, and bring the HME Nitro Vision AI cameras online. The Nitro Vision AI consists of multiple IP cameras (depending on location and store needs), 1 VPU, and 1 PoE Switch connected to a ZOOM Nitro System via the store's network router/switch.

While there are numerous site floor plans and structural differences, the installation is essentially the same for all stores. Sites are first surveyed and approved before installation. If physical restrictions are missed and present themselves during installation, the issue must be quickly escalated and resolved by the HME Support team.

CAMERA PLACEMENT IN DRIVE-THRU LANES AND MOBILE SPACES

Cameras are used to detect and track vehicles in a drive-thru or in a mobile space. Fig 1 shows an example of multiple possible locations.

Drive-Thru

In this setting, cameras are positioned to capture multiple zones as defined here.

Extended Stack: (The teal area in Fig. 1.) This is an area behind the pre-menu stack that extends it.

Pre-Menu Stack: (The red area in Fig. 1.) This is an area behind the pre-menu where customers can potentially exit the lane and drive off if they decide not to wait.

Pre-Menu: (The orange area in Fig. 1.) This is the area where a single car next in line is waiting just before reaching the order point.

When installing cameras in a drive-thru, consideration must be given to the drive-thru layout. It will either have a captured or an uncaptured lane.

Captured lanes: These lanes have a physical boundary along their length, preventing cars from pulling out and driving off. These boundaries can be curbs, walls, railings, or hedging. (Fig. 1 has curbs). Captured lanes are also narrow enough so that a car cannot overtake the car in front of it. The only way a car can escape a captured lane is by reversing out of it.

Pre-Menu Stack: In a captured lane, it begins at the end of the Pre-Menu and extends back to capture a line of cars, sometimes a few cars deep.

Pre-Menu: In a captured lane, it begins at the start of the captured lane just before the order point and extends back, ideally one car length before the order point.

Uncaptured lanes: these lanes lack a physical boundary or are wide enough for cars to pull out of a queue and drive off at any point in the drive-thru.

Pre-Menu Stack: In an uncaptured lane, it begins at the end of the Pre-Menu and extends back to capture a line of cars, sometimes a few cars deep, to a point where proper detection becomes unreliable or traffic for the drive-thru is no longer discernible.

Pre-Menu: In an uncaptured lane, ideally, it is as close to the order point (but before it) as possible. It must also be one car length long (approx. 20 feet (6.1 m)).

Pick-Up Zones

These are the Blue and Purple areas in Fig. 1. Cameras should be installed to see as many mobile or pull-forward spaces as possible, up to four mobile spaces per camera (eight maximum with two cameras), up to two full-forward spaces (two maximum), or a combination of both. Cameras should be positioned to view the front or back of these pick-up zones, as side views can be problematic due to obstructions. For example, a large (tall) vehicle might block the camera's view of a detection zone if the zone is far from the camera with other available parking spaces in between.

GENERAL RULES GOVERNING THE PLACEMENT OF CAMERAS:

- The camera needs to be close enough to track cars passing through the Pre-Menu Stack and reaching the Pre-Menu. At least one car needs to be visible in the Pre-Menu and preferably several within the Pre-Menu Stack area.
- Views should be free from obstacles blocking cars in the Pre-Menu and Pre-Menu Stack. The order point can be within the camera's view, as long as it does not block the Pre-Menu Zone view. Small or low obstacles may be acceptable as long as a large percentage of the cars are not continuously blocked by vehicle movement.
- If cars turn as they first move through the Pre-Menu Stack and into the Pre-Menu zone (as in Fig. 1), it is best to position the camera to see cars from the side and the front.
- For mobile spaces, positioning the camera toward the front or back of the space is preferable, as side views may be blocked by other large vehicles in adjacent spaces.

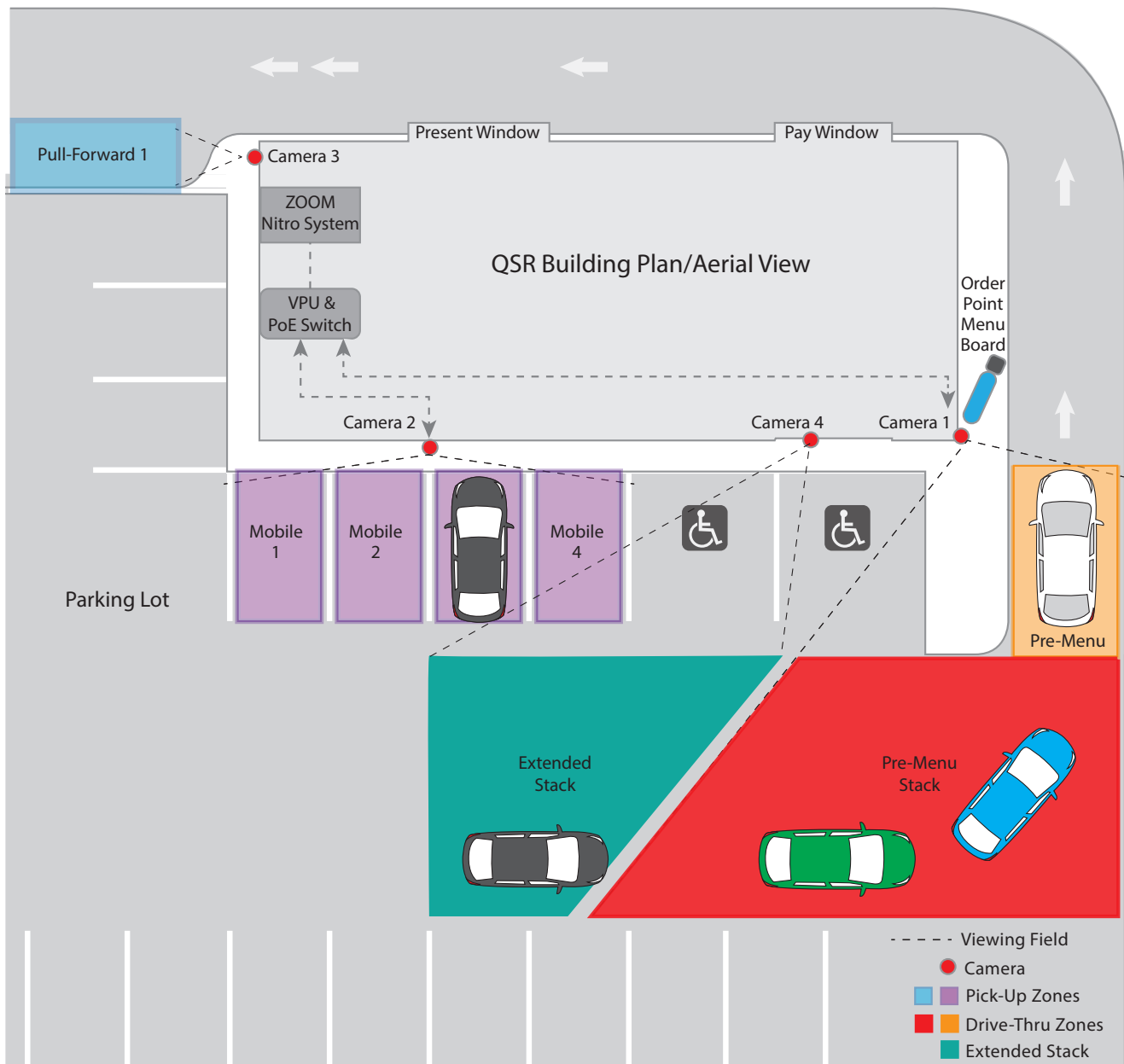

Fig. 1

SYSTEM WIRING DIAGRAM

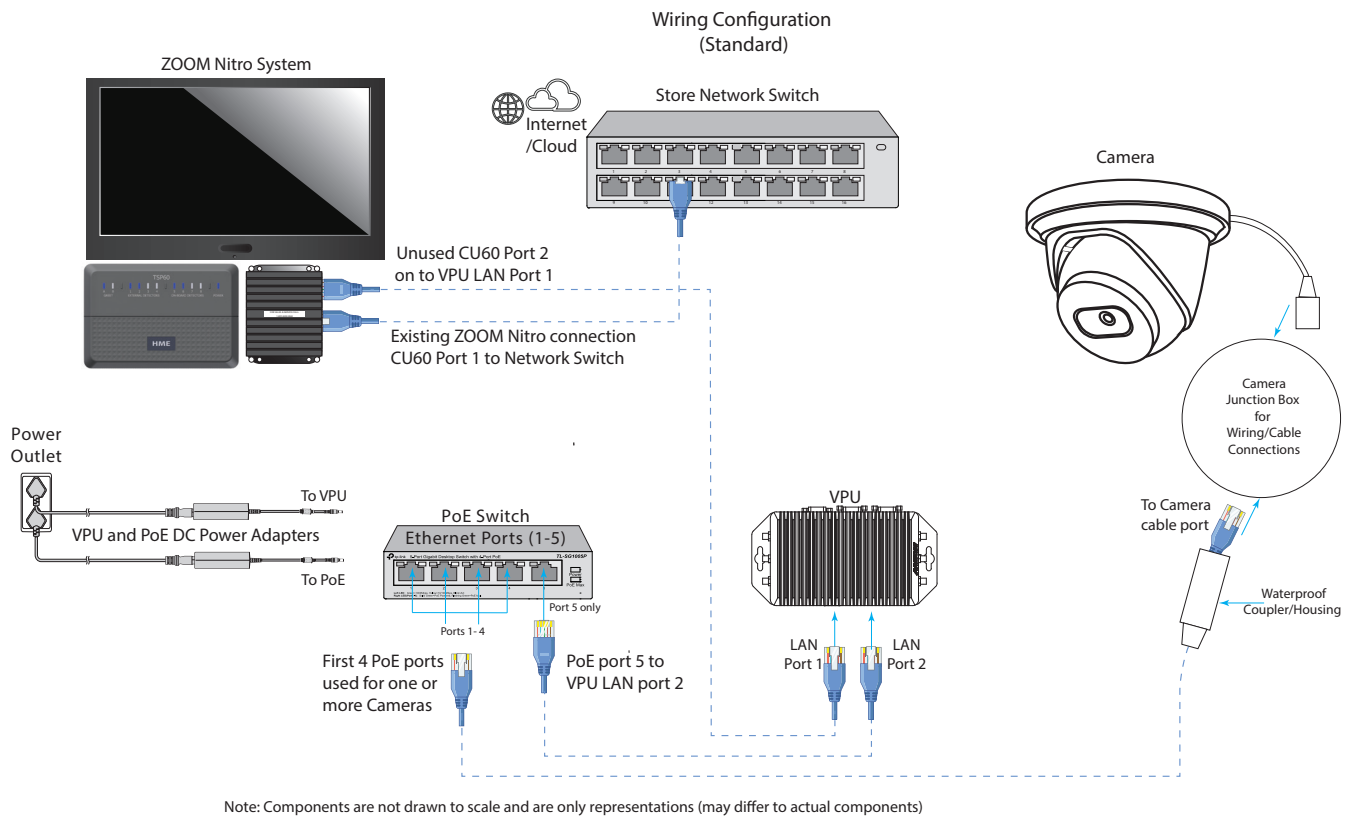

Fig. 2

INSTALLATION

BEFORE YOU BEGIN

- Inventory the parts shipped to the site and compare them to the packing slip included in the box. Notify your HME Support IMMEDIATELY if any equipment is missing or damaged in shipment.
- Refer to the work order for approximate camera locations, zones, and other pertinent information.
- Before installing the equipment, determine the routing path of the cables between the devices. Also, verify a device's proximity to vacant power outlets and the store's network switch.
- Use a cable tester to test the Ethernet cable before running it to make sure the cable is good.

RUNNING CABLES

Take into consideration the following precautions when running cables.

- Create a service loop when running the camera Ethernet cable.
- Excess cable should be coiled in the ceiling
 - DO NOT leave excess exposed or coiled on the wall
- Seal penetration point after pulling cable. Use an external waterproof sealant.
- Verify the Ethernet cable to the camera has the waterproof coupler installed.

INSTALL ALL SYSTEM COMPONENTS: CAMERA

Install the junction box and the camera:

1. Refer to the installation work order for the suggested camera placement.
Note: Prior to installation, ensure the installation environment can support at least three times the camera's weight.
2. Remove the contents of the accessory box containing the junction box.
3. Peel and place the junction box mounting sticker onto the mounting surface where the junction box will be mounted. See Fig. 3.



NOTE: The ideal mounting height is between **12 and 14 feet** (3.7 - 4.3 m). Also, the area to be captured by a mounted camera should be within **60 feet** (18.3 m) of the camera's position, as this is the maximum limit recommended to ensure data integrity.

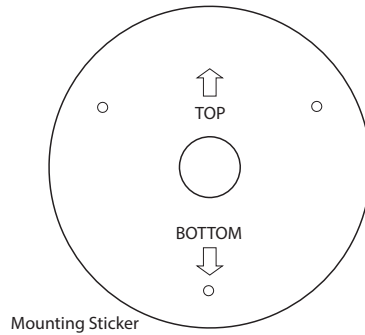

Fig. 3

4. Drill holes according to the mounting sticker. If running wires/cables through a wall/ceiling, a 3/4" paddle or masonry bit can be used to drill the center portion of the mounting sticker.
5. Remove the lid from the junction box and use the included hardware. Insert the included wall anchors into the holes. Use a Phillips head screwdriver and screws to mount the junction box (Fig. 4).

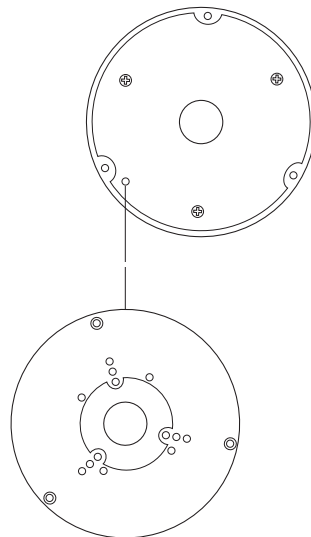

Fig. 4

- Pass the one end of the Ethernet cable through the wall opening just drilled (the majority of the cable should be inside the building, with just enough slack on the outside to make the camera connection and seal with the waterproof coupler). The Ethernet cable should pass through the mounted junction box and the lid you removed. Remove the black grommet at the center of the lid to do so; it will be reinserted later.



Fig. 5

- Remove the camera and contents from the camera box.
- Connect the included waterproof coupler to the Ethernet cable and camera cable as follows:

NOTE: Most commercial Ethernet cables use a molded strain relief that cannot be separated from the RJ45 plug, so only use the outdoor cable provided.

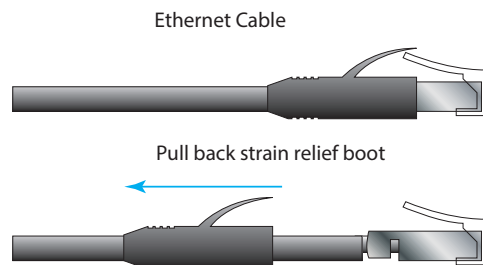

Fig. 6

- Pull back the strain relief boot covering the RJ45 plug on the outdoor Ethernet cable.
- Install the four-piece waterproof coupler that came with the camera. Three pieces (1, 2, and 3) are installed on the Ethernet cable, while the fourth piece, the thin washer (4), is inserted over the RJ45 port of the camera cable. See Fig. 7.

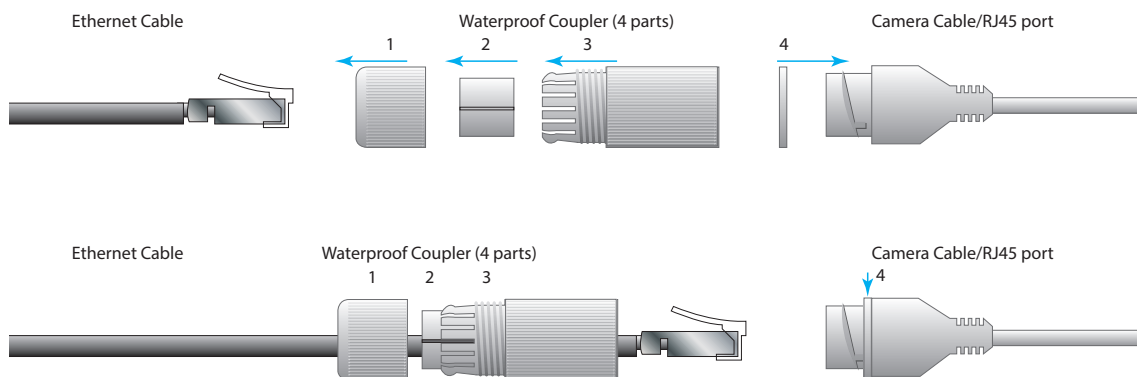

Fig. 7

- Connect the Ethernet cable to the RJ45 port on the camera cable.

12. Assemble the plastic waterproof coupler together to seal the connection. See Fig. 8 and Fig. 9.

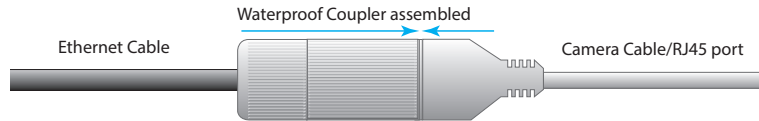

Fig. 8



Fig. 9

13. Once the cables are connected and sealed, push and coil them back into the junction box.

14. Reattach the lid to the junction box using the included hex key.

15. Use the included Torx wrench (from the camera box) to remove the security screw on the front of the casing. See Fig. 10.



Fig. 10

16. This will disassemble the camera from its case (Fig. 11).



Fig. 11

17. Align the four holes on the camera bottom bracket with the mounting holes on the junction box lid, and attach it using the socket-head cap screws and hex key from the junction box hardware bag. See Fig. 12 and Fig. 13.

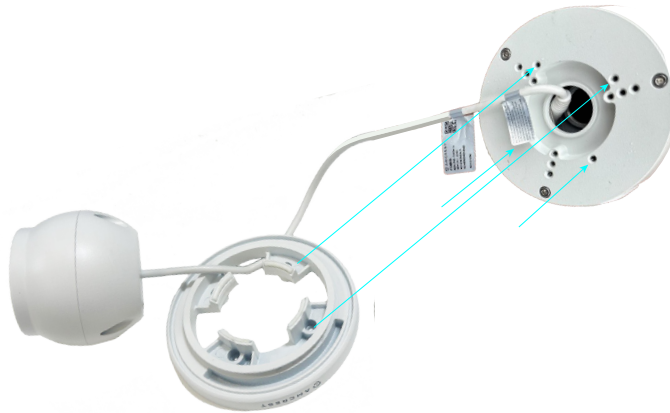

Fig. 12



Fig. 13

18. Feed any cable slack back into the junction box. Place the black grommet (removed in step 6) onto the exiting cable (the grommet is split and can be opened). Press the grommet back into the junction box lid to seal it.
19. Place the top portion of the casing over the camera and bottom bracket, and use the Torx wrench to tighten the security screw back onto the casing. Do not overtighten the security screw, as it may not be properly secured. The camera is now securely mounted to the junction box.

INSTALL ALL SYSTEM COMPONENTS: PoE SWITCH

The PoE switch can be placed on a shelf or wall-mounted. To wall mount:

1. Place the template against wall (see end of the guide for template).
2. Use a punch, pencil, or other pointed marker to punch through the cross-hairs on the template to mark the wall for the screw positions.
3. Drill holes and insert anchors and screws, but leave enough of a gap between the screw heads and wall so that the PoE switch can be mounted over the screw heads (approximate gap 0.125" (3.2 mm)).
4. Mount the PoE switch over screw heads until flush against the wall, and slide the PoE switch down until it is seated on the screw shanks to secure it in place.



INSTALL ALL SYSTEM COMPONENTS: VPU

The VPU can be placed on a shelf or wall-mounted. To wall mount:

1. Hold the VPU against the wall and use a pencil or punch to mark the wall for the screw positions.
2. Drill holes and insert anchors and screws, but leave enough of a gap between the screw heads and wall so that the VPU can be mounted over the screw heads (approximate gap 0.125" (3.2 mm)).
3. Mount the VPU over screw heads until flush against the wall and slide the VPU down until it is seated on the screw shanks to secure it in place. Tighten if necessary.



CONNECT ALL SYSTEM COMPONENTS

Connect Ethernet cables (see work order for details).

- Camera(s) connect to the PoE switch, ports 1 - 4 (in any order).
- PoE switch port 5 is connected to VPU port 2 (right LAN port next to USB ports, Fig. 14).
- VPU port 1 (left LAN port next to power connector) connects to the ZOOM Nitro CU60 port 2 (remove RJ45 port cap to access, if covered).
- Connect power adapters to the devices. Power on the PoE switch (with cameras connected) first. Then wait a minute to power on the VPU last.

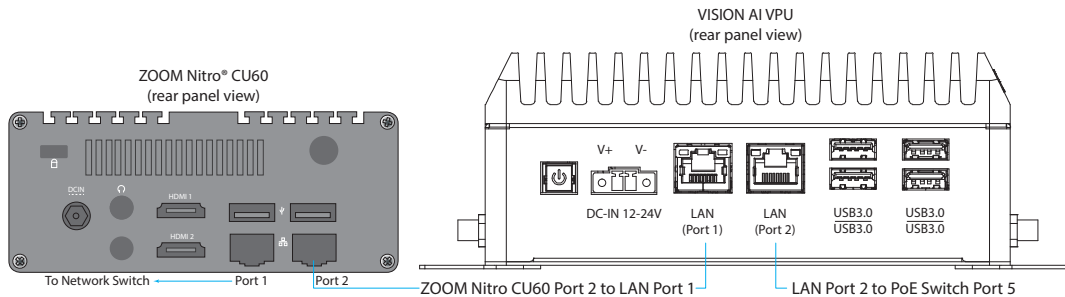

Fig. 14

NOTE: The PoE and VPU should not be mounted in the store's IT enclosure (system/network rack) unless a designated place has been allocated by the store's IT administrator. Such enclosures may not provide adequate cooling/ventilation for the VPU. Rack maintenance and the number of cables terminated at this point can also interfere with connection integrity.

VERIFY OR ADJUST CAMERA VIEW VIA ZOOM NITRO

1. Connect a USB mouse (type A) to the vacant USB port on the ZOOM Nitro CU60.
2. Access the Store's ZOOM Nitro. Go to the LOGIN page and log in using the installer's password.

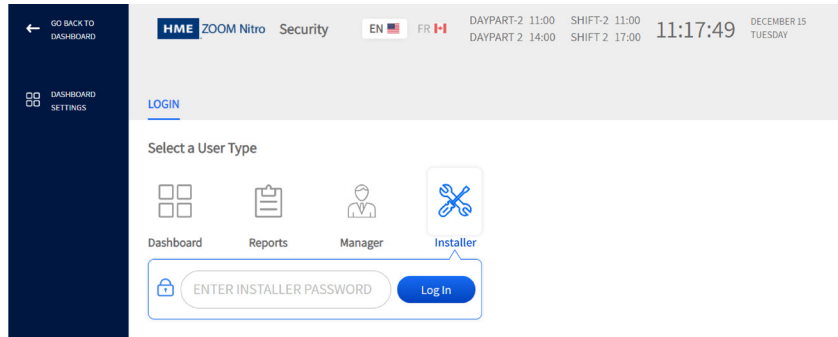

Fig. 15

3. Go to the DETECTORS page and select the Camera tab, then toggle the switch to Enable the camera.

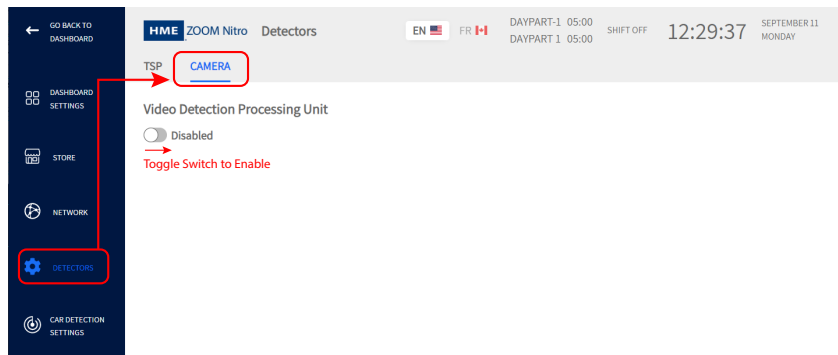

Fig. 16

Note: If the following error message appears, go to ““Help and Troubleshooting” on page 28 to find the solution to this problem.

You do not have access to Nitro Vision AI. Please reach out to your HME Sales contact for more information

4. The Camera page will populate. Click/tap the “Refresh All Cameras” button (Fig. 17).

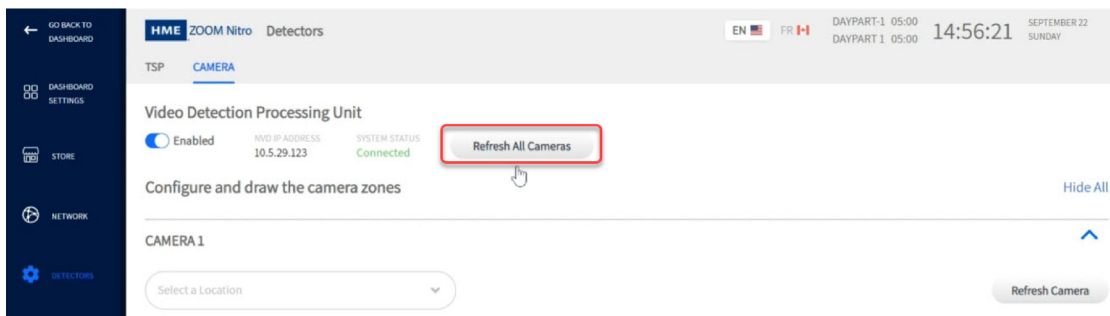

Fig. 17

5. With the Camera Preview now displayed (Fig. 18), determine if the view is good enough to draw zones. If not, the camera angle will need to be adjusted. After each adjustment, use the “Refresh All Cameras” button to refresh the preview image to the newly adjusted angle.

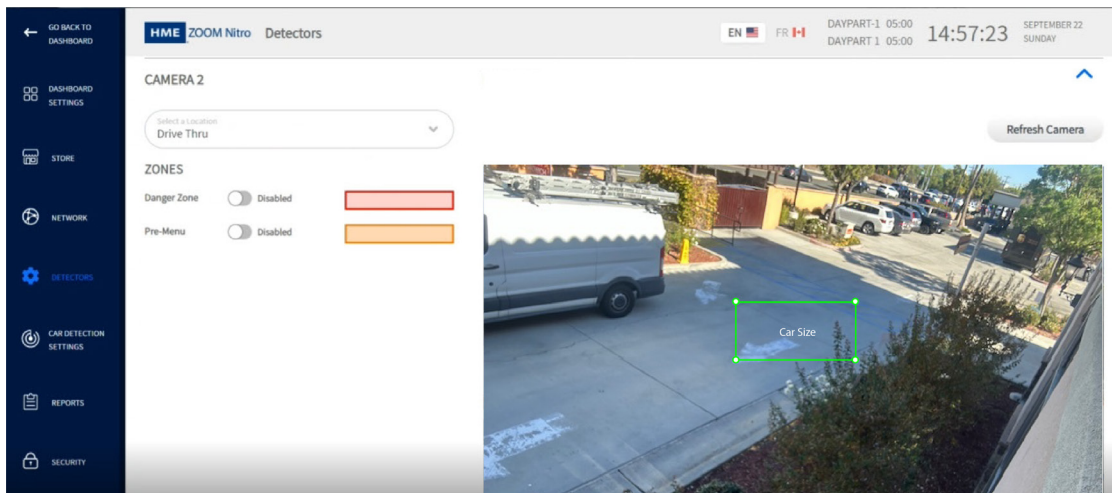

Fig. 18

6. Once the view is good, proceed to the next section.

ZOOM Nitro Setup, Drawing, and Configuring Zones

1. If you are already logged in to ZOOM Nitro from the previous section, skip to step 4. Otherwise, access the Store's ZOOM Nitro. Go to the LOGIN page and log in using the installer's password.

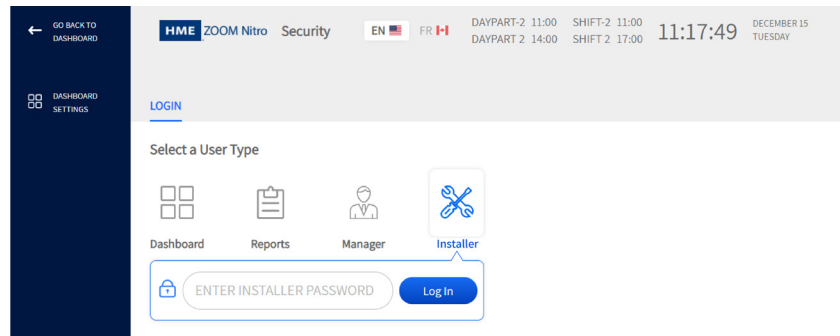

Fig. 19

2. Go to the DETECTORS page and select the Camera tab, then toggle the switch to enable the camera. Also see **Note** under step 3 of “Verify or Adjust Camera View via ZOOM Nitro” on page 10.



Fig. 20

3. The Camera page will populate. Click/tap the “Refresh All Cameras” button to see preview (Fig. 21).

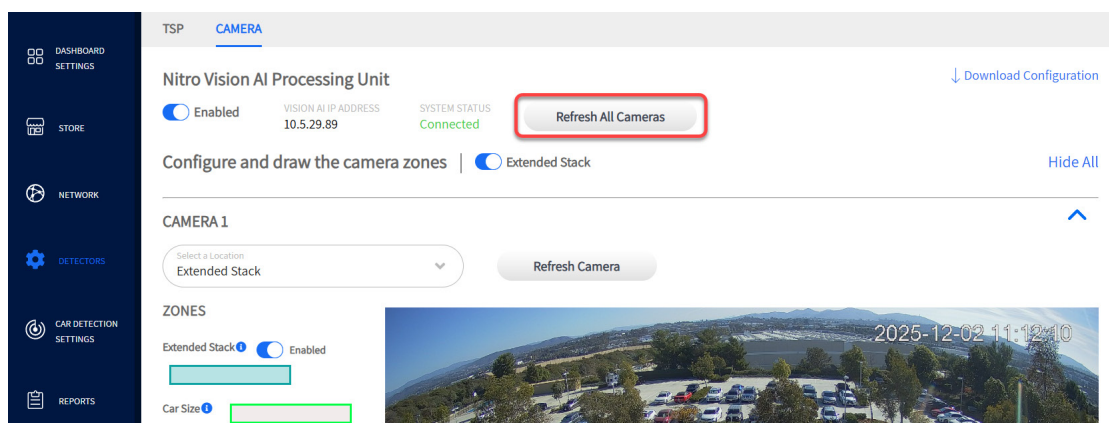

Fig. 21

4. Select a location from the drop-down list under CAMERA 1.

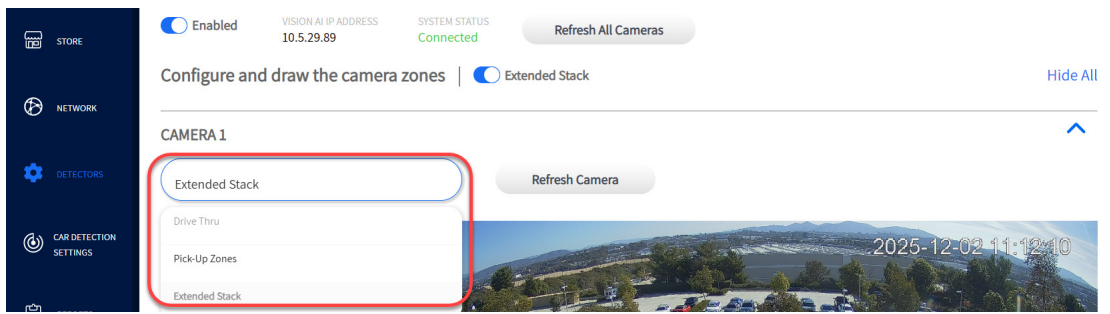

Fig. 22

- The location options are Drive-Thru or Pick-Up Zones. Once an option is selected, the page will populate with zones. Steps 6 - 11 cover Pick-Up Zones, while steps 12 - 17 cover Drive-Thru, and Extended Stack.

Pick-Up Zones

- If Pick-Up Zones is selected, toggle the switch to enable a zone, and a polygon (in purple or blue) will appear in your camera view. Fig. 23 shows Mobile 1, 2, and 3 enabled, so three purple polygons appear in the camera view. When you move the cursor over a polygon, it turns into a hand that lets you drag it into position.

NOTE: With Pick-Up Zones, even though six zones (four mobile and two pull-forward) are listed onscreen under a camera. A single camera can only support a maximum of four zones. Up to four mobile spaces, or up to two pull-forward spaces, or a combination of both, totaling four when all are within the field of view of that camera.

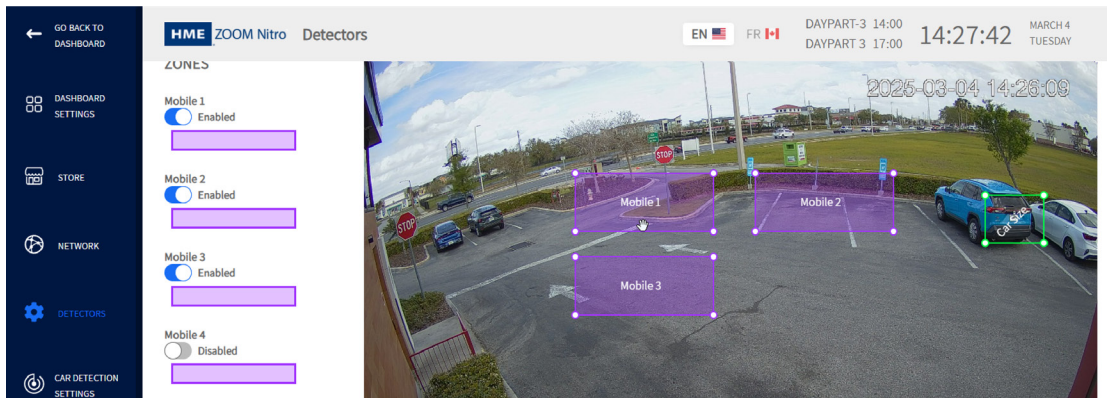

Fig. 23

- The polygon has four adjustable vertices, one on each corner. After moving the box into a parking space, grab any corner vertex and adjust the polygon to match the parking space. See Mobile 1 in Fig. 24.

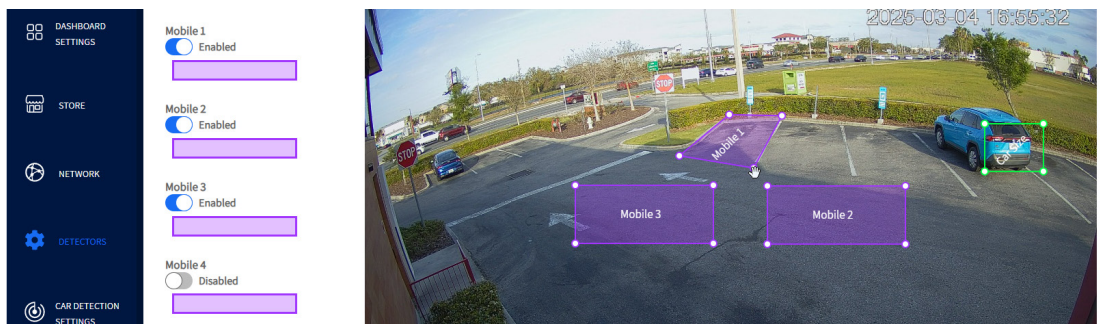

Fig. 24

- Repeat the process for additional mobile spaces (up to four total per camera). Fig. 25 shows three mobile spaces configured. For easy identification, it is best practice to assign the space numbers in order (left to right here).

NOTE: When Pick-Up Zones are adjacent, like the ones shown in Fig. 25, the adjacent sides should overlap (i.e., no gaps can exist between the polygons). See first bullet point in Step 13. Gaps can exist if the polygons are not side-by-side (i.e., separated by a parking space, or by at least 3 feet). Pull-Forward and Mobile spaces can also alternate side-by-side. For example, the layout in Fig. 25 could be configured with two Mobile spaces and a Pull-Forward space in between (the space currently occupied by Mobile 2).

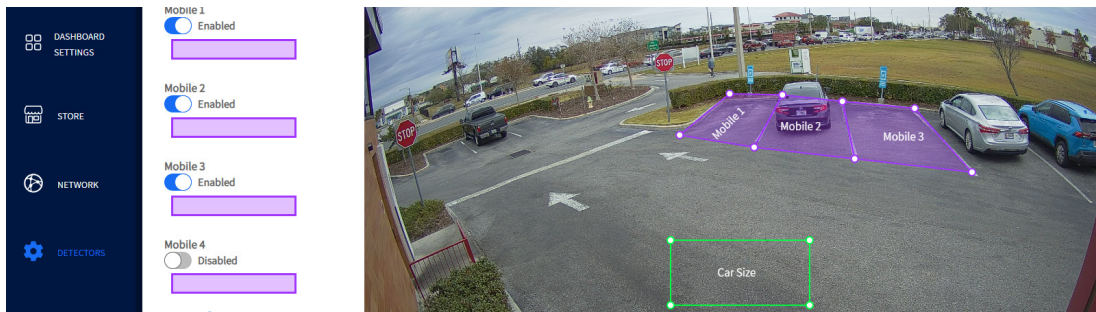

Fig. 25

- The Car Size polygon (in green) is used as a reference to approximate a car’s size. Any average-sized car (e.g., a sedan) can be used, provided it is close to the mobile spaces. Place the box over a car and adjust it using the corner points to match the car’s size. If no cars are present, a mobile space can be used to approximate the size of a car (the installer can also use their car if it is an average-sized vehicle). If you sized the car using a Mobile space, move the Car Size polygon out of the Mobile space drawing before saving. See Fig. 26.

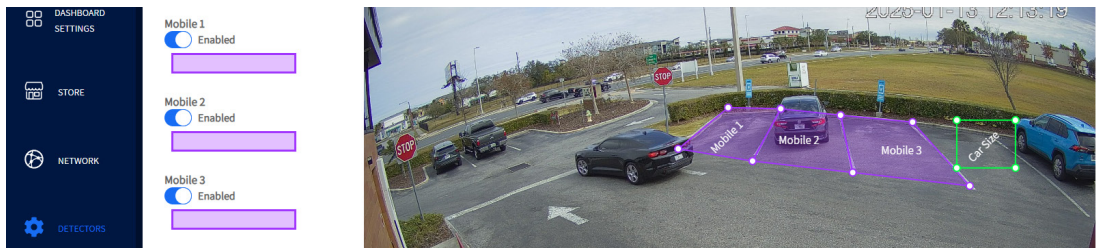

Fig. 26

- Once the car size and zones are configured, click/tap the “Save” button.
- Pull-Forward spaces (blue) are also configured here like mobile spaces. The system only supports a maximum of two Pull-Forward spaces.

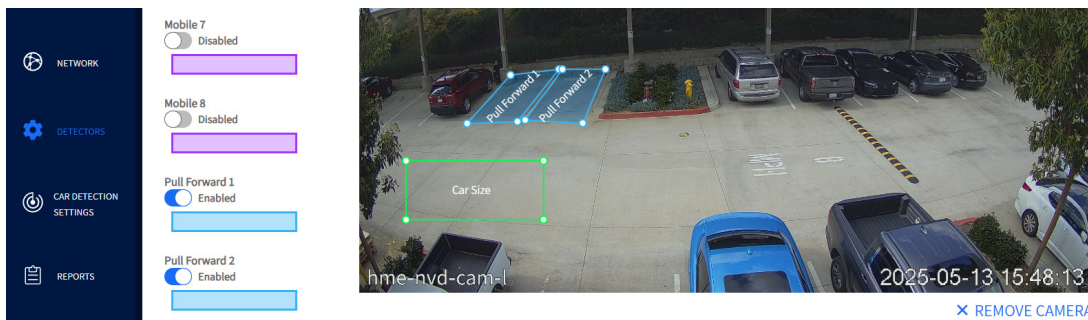

Fig. 27

Drive-Thru

12. If Drive-Thru is selected from the Location drop-down list, two zones appear: the Pre-Menu Stack and Pre-Menu zone. Toggle both switches to enable both zones, and two polygons (red and orange) will appear in your camera view like those shown in Fig. 28.

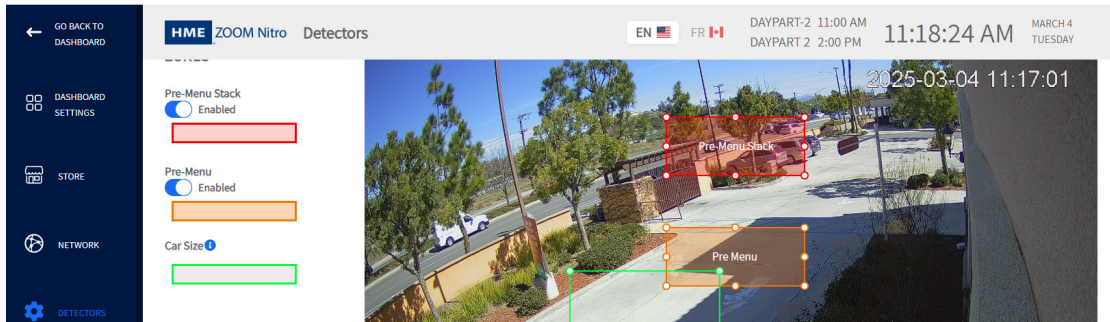

Fig. 28

13. When you move the cursor over a box, it turns into a hand that lets you drag it into position. The polygons have eight adjustable vertices, one on each corner and one on each side. After moving the box into position, grab any vertex and begin adjusting the box to match the Pre-Menu and Pre-Menu Stack zones you desire to capture. Fig. 29 shows both zones drawn to capture the drive-thru lane events.

Things to consider when configuring zones:

- Both zones must butt up against each other with no gap between them. The best way to accomplish this is by moving the adjoining vertices from one box on top of the corresponding vertices of the other box until both contacting edges overlap.
- The Pre-Menu Stack should be a few cars deep, if possible, and should capture only cars entering the drive-thru. So, if done in a parking lot with additional parking spaces and traffic lanes, don't make the polygon too large or sloppy (as they may capture stray cars outside the zones).
- The Pre-Menu should be at least one car length before reaching the menu board and only wide enough to capture that one lane.
- Avoid areas that can block the camera's view of cars. While small occlusions might be acceptable if a large portion of the vehicle remains visible, large occlusions can lead to inaccuracies.

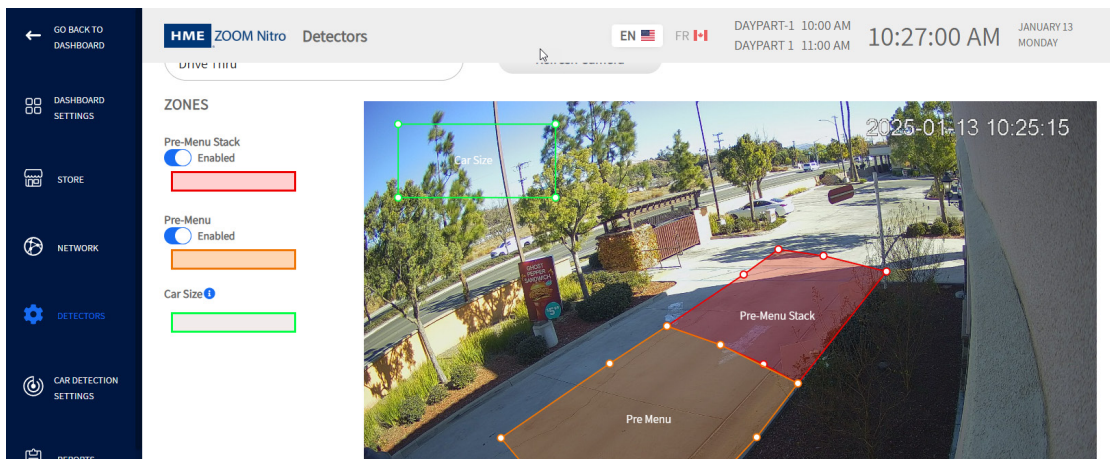

Fig. 29

14. The Car Size polygon (in green) is used as a reference to approximate a vehicle's size. Any average-sized car (e.g., a sedan) close to the zones can be used. Drag the box to one of the captured zones. Place the box over the car and adjust it using the corner vertices to match the vehicle's size. If no cars are present, the installer can use their car if it is an average-sized vehicle. See Fig. 30.

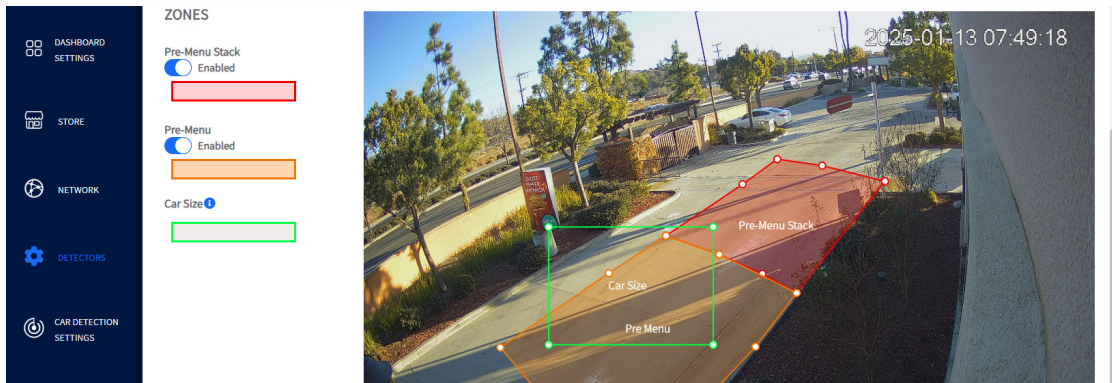

Fig. 30

15. Once the car size and zones are configured, move the Car Size polygon out of the Pre-Menu and Pre-Menu Stack area before saving. Click/tap the “Save” button.
 Fig. 31 shows an example of a Y Lane. It is configured the same way a Single Lane is configured. The only difference is that it has two Pre-Menu zones instead of one.

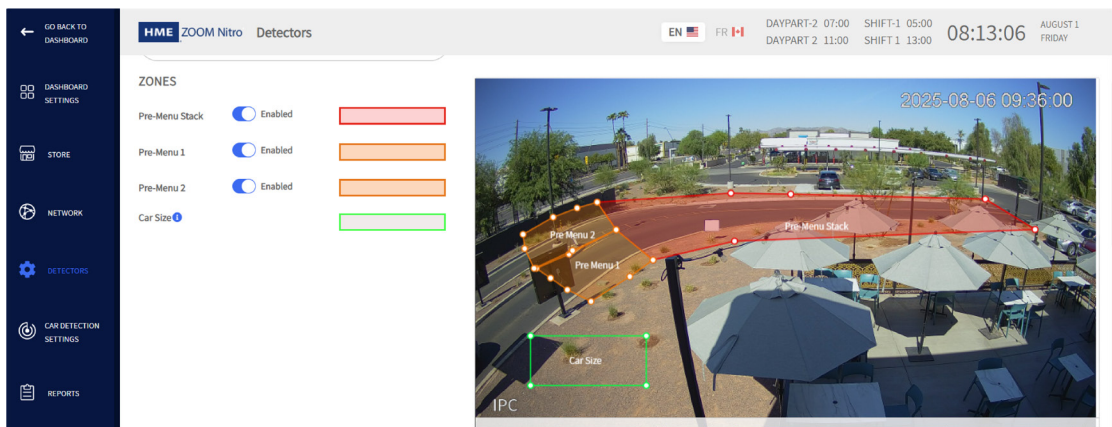

Fig. 31

Drive-Thru with Extended Stack

16. Fig. 32 shows the CAMERA 1 drop-down list when the Extended Stack is enabled (the Extended Stack option does not appear in the drop-down list if the toggle is disabled). While Extended Stack requires a dedicated camera, it must be used in conjunction with another Drive-Thru camera (i.e., it does not function independently).

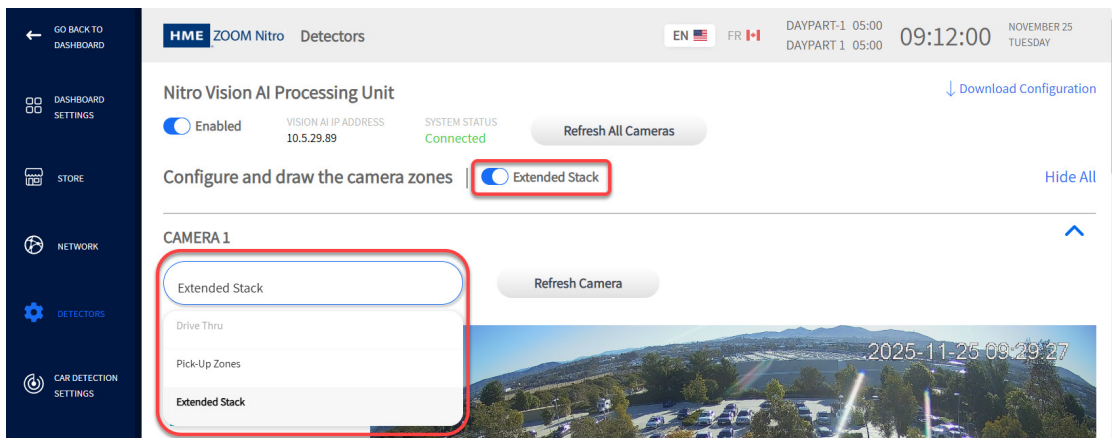

Fig. 32

17. Extended Stack allows a store to capture more vehicles beyond the Pre-Menu Stack, thus providing an extended range of metrics. It is combined with the Pre-Menu Stack data and treated as such (not as a separate metric on the dashboard). While the Extended Stack should be positioned close to the Pre-Menu Stack, it can have a small gap (unlike the Pre-Menu, which must butt up against the Pre-Menu Stack with no gap). This is because it uses a separate camera to monitor a single zone. Fig. 32a shows the drive-thru camera with Pre-Menu and Pre-Menu Stack configured, while Fig. 32b shows the Extended Stack camera covering the area to the right of the Pre-Menu Stack with the Extended Stack configured.



Fig. 32a

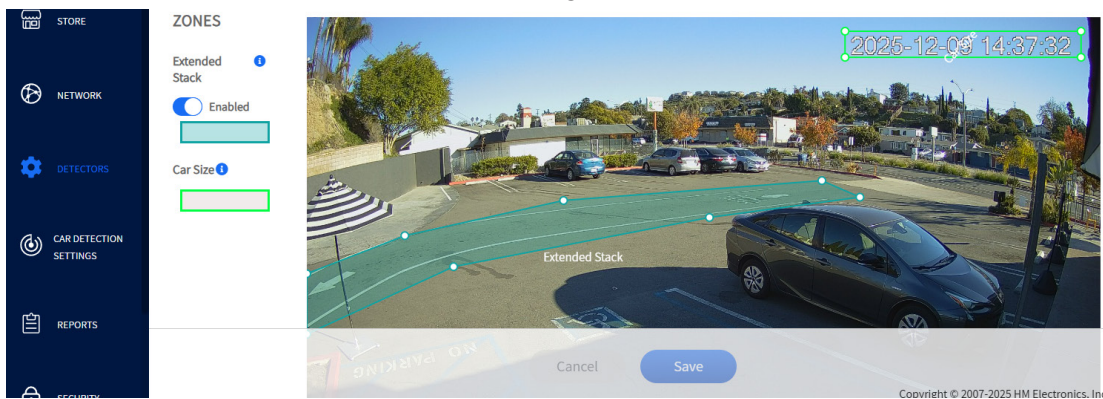

Fig. 32b

Things to consider when configuring the Extended Stack:

- The Pre-Menu and Pre-Menu Stack zones should be drawn first before drawing the Extended Stack.
- The Extended Stack camera view must be positioned before the Pre-Menu Stack so that the Pre-Menu Stack becomes the middle zone between Pre-Menu at one end and the Extended Stack at the other.
- If overlapping, the camera view for Extended Stack must not overlap the Pre-Menu/Pre-Menu Stack camera view by more than 25%. (Do not confuse this view with the zone polygon that is adjusted within the camera view.)
- If not overlapping, any gap between the camera views of both cameras cannot exceed two cars. (Likewise, do not confuse this view with the zone polygon that is adjusted within the camera view.)
- The zone must be turned on before mapping.
- Extended Stack is one zone, and the polygon once drawn cannot overlap or touch the Pre-Menu Stack polygon.
- Extended Stack should be drawn in an area where cars will queue as they enter the Pre-Menu Stack and Pre-Menu zones. It doesn't matter if cars pass through the Extended Stack without stopping, since the system discards such cars.
- Detection will still work if a car is only detected moving from the Pre-Menu Stack into the Pre-Menu zone, but was not detected in the Extended Stack.

ERROR PROMPTS WHEN CONFIGURING POLYGONS

When polygons are being customized for a store, any invalid adjustments will result in a red prompt box at the bottom of the camera view. You will not be able to save the configuration until the error is rectified. The following is a list of possible errors and what they mean:

- **Polygons do not share at least two points, Pre-Menu Stack with Pre-Menu. Please try again.**
The pre-menu and pre-menu stack zones must touch each other with at least two overlapping vertices. The best practice is to drag the vertex of one polygon on top of the other polygon's vertex so that they now appear as one vertex, i.e., once both zones are drawn to capture the pre-menu and pre-menu stack areas, at least one edge on one polygon will butt up against the edge of the other polygon (no gap can exist between them). If this error occurs, readjust so that at least two vertices (one edge) of one polygon sit on top of two vertices (one edge) of the other adjoining polygon.
- **Vertices must be within the resolution of camera 2 at vertices 2. Please try again.**
All vertices must be within the area displayed in the camera view. For example, a mobile spot polygon has four corner vertices that can be adjusted to change its shape. All four vertices must remain visible in the camera view. In this example, "vertices 2" is the lower-left vertex of the polygon and has been dragged out of the camera view so it is no longer visible (vertices are numbered by the system, beginning at the upper-left vertex and proceeding counterclockwise). Move the vertex back into the camera view to rectify.
- **Crossing line detected in Pre-Menu zone. Please try again.**
When one vertex is dragged across a side of the polygon to which it belongs. Readjust so that it no longer crosses the edge of the polygon.
- **Invalid overlap detected in camera 2. Please try again.**
When the vertex or vertices of one polygon are dragged into the area occupied by another polygon, readjust so that they don't overlap.

VISION AI DETECTOR MAPPING ON ZOOM NITRO

Once the camera zones have been defined, additional parameters need to be configured on the ZOOM Nitro dashboard. Step 1 covers Single or Y Lane. Step 2 covers Mobile, and Step 3 covers Pull-Forward.

NOTE: Take a snapshot of the dashboard before making changes, so the original settings can be restored if any configuration is lost or accidentally changed.
A CU reboot is required whenever any Lane Configuration settings or Detection Types are added or removed. CU cable swaps to Ports 1 and 2 also require a CU reboot.

1. For Drive-Thru detection: Go to CAR DETECTION SETTINGS>LANE DETECTORS.
Under 2. Add/Remove Detection Types >PRE-MENU, click/tap the + (Add) tile. (Add a second for Y Lane.)
Under 3. Configure Detector Mapping > Pre-menu row, select from the drop-down lists.
Under PROCESSOR: Select VPU.
Under DETECTOR: Select the appropriate camera (if more than one is used).
Under DISPLAY NAME: Enter a descriptive name for the camera.
Under QUEUE SIZE: Select queue size based on how many cars can fit between the Pre-Menu and Menu (usually 1, but this field is configurable if more than one car fits).
Under DELAY: This sets the minimum time the car must remain in the zone before it is detected and processed.
Under DISCARD: Adjust the amount of time if you need to verify that the vehicle present is a real customer and not an accidental trigger caused by a passing vehicle.

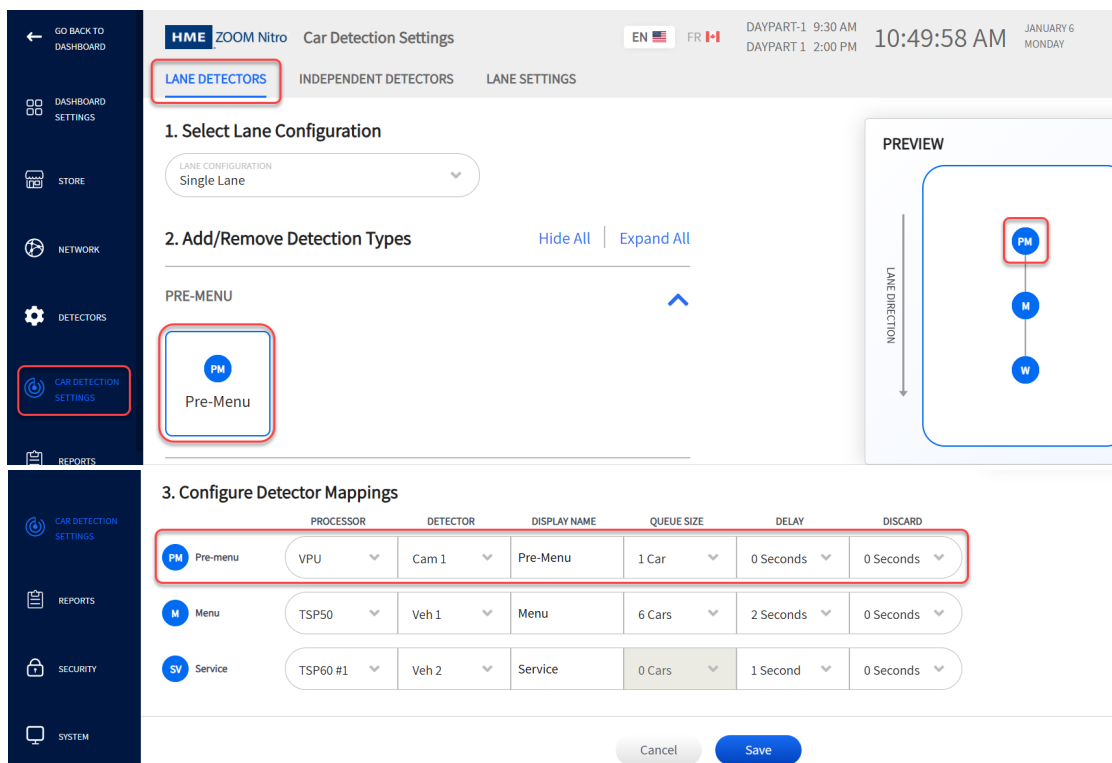

Fig. 32

2. For Mobile detection: Go to CAR DETECTION SETTINGS>INDEPENDENT DETECTORS.
Use the +ADD icon to add rows based on the number of mobile spaces used (a maximum of four per camera). The example in Fig. 25 shows three mobile spaces, which are all added here in Fig. 33.
Under PROCESSOR: select VPU.

Under DETECTOR: select the appropriate mobile number (if more than one is used).
 Under DISPLAY NAME: This is an editable field, so give the mobile space a descriptive name.
 Under DELAY: This sets the time the car must remain in the zone before it is detected and processed.

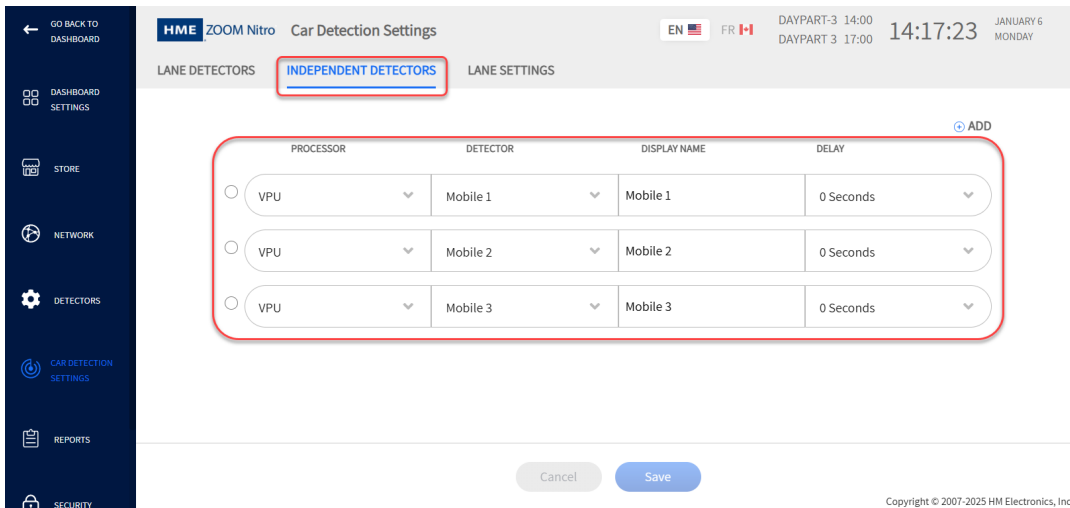

Fig. 33

3. For Pull-Forward detection: Go to CAR DETECTION SETTINGS>LANE DETECTORS.

Under 2. Add/Remove Detection Types >PULL-FORWARD, click/tap the + (Add) tile. See Fig. 34.

Under 3. Configure Detector Mapping >Pull-Forward row drop-down lists. See Fig. 35.

Under PROCESSOR: Select VPU.

Under DETECTOR: Select the appropriate camera (if more than one is used, Cam2 in this example).

Under DISPLAY NAME: Enter a descriptive name for the camera.

Under QUEUE SIZE: 0 (inactive field not applicable to Pull-Forward spaces).

Under DELAY: The default is 0 seconds. Select the time it takes for the vehicle to go from the previous detector to the pull-forward space (3 seconds in this example).

Under DISCARD: The default is 0 seconds. Adjust the time if you need to verify that the pull forward is real and not an accidental trigger caused by a passing vehicle (3 seconds in this example). This sets the minimum amount of time a vehicle must stay in the space to be treated as valid.

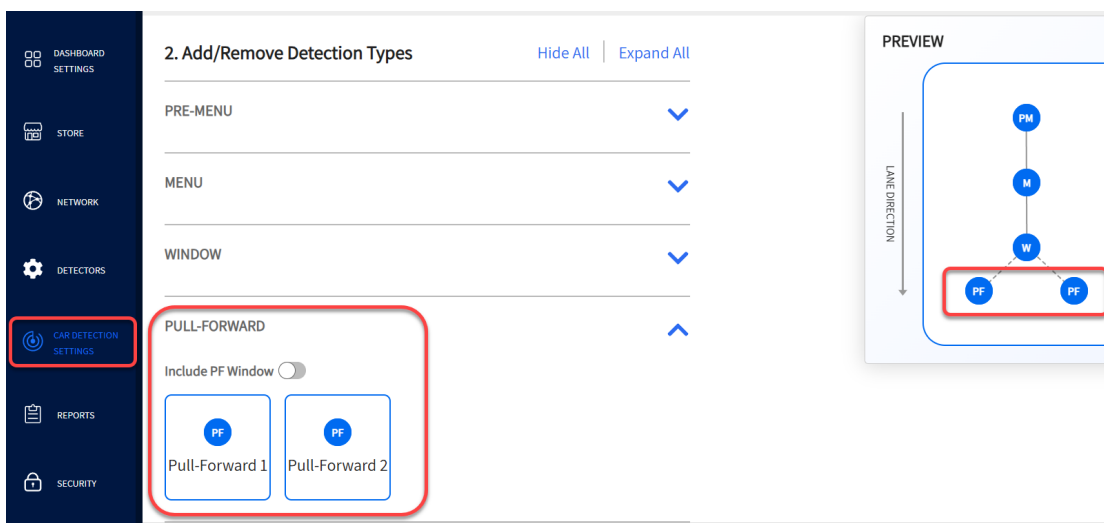

Fig. 34

3. Configure Detector Mappings

	PROCESSOR	DETECTOR	DISPLAY NAME	QUEUE SIZE	DELAY	DISCARD
PM Pre-menu	VPU	Cam 1	Pre-Menu	1 Car	0 Seconds	0 Seconds
M Menu	TSP60 #1	Veh 1	Menu	5 Cars	2 Seconds	0 Seconds
SV Service	TSP60 #1	Veh 2	Service	0 Cars	1 Second	0 Seconds
PF Pull-Forward	VPU	Cam 2	Pull-Forward 1	0 Cars	3 Seconds	0 Seconds
PF Pull-Forward	VPU	Cam 2	Pull-Forward 2	0 Cars	3 Seconds	0 Seconds

Fig. 35

4. Fig. 36 shows where the Mobile spaces are displayed on the dashboard. The camera view in Fig. 25 shows a vehicle in Mobile space 2, which is reflected on the dashboard. If Pull-Forward spaces are used, they will appear in the same area on the dashboard (see Fig. 37).

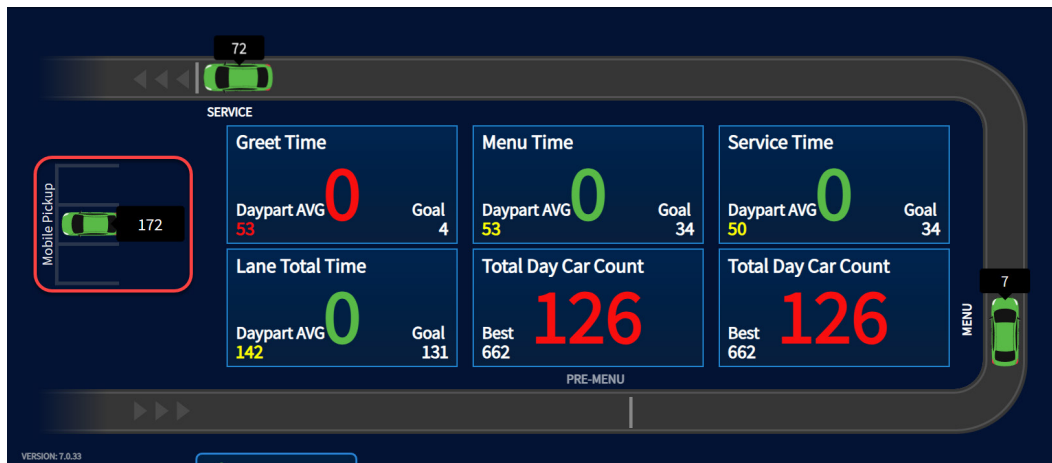

Fig. 36

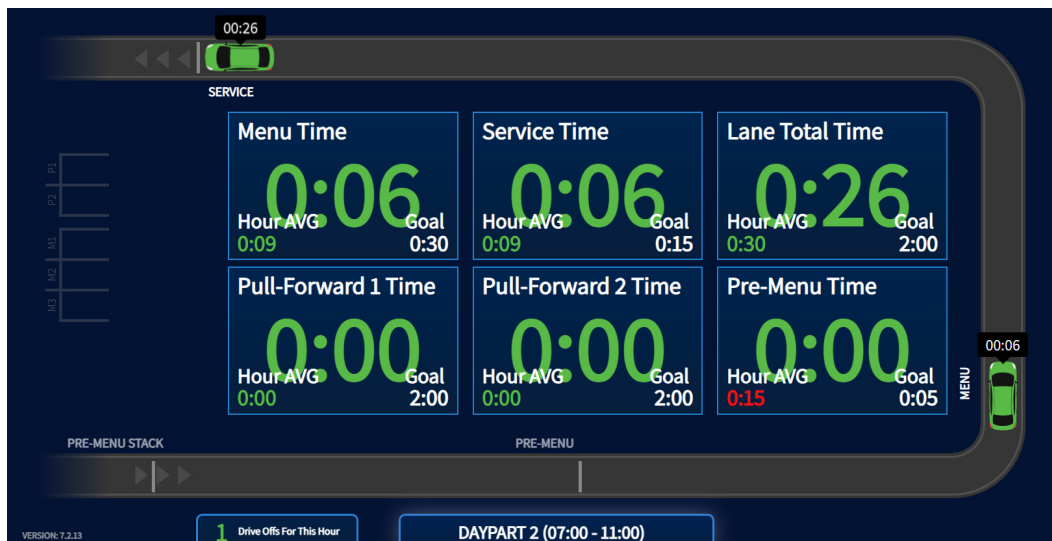

Fig. 37

- For Lane Total: Go to CAR DETECTION SETTINGS > LANE SETTINGS
If the customer wishes to include Pre-Menu events as part of their lane total. In the START TOTAL field, select Pre-Menu from the drop-down list. Also, set the START AT field to Arrival. See Fig. 38.

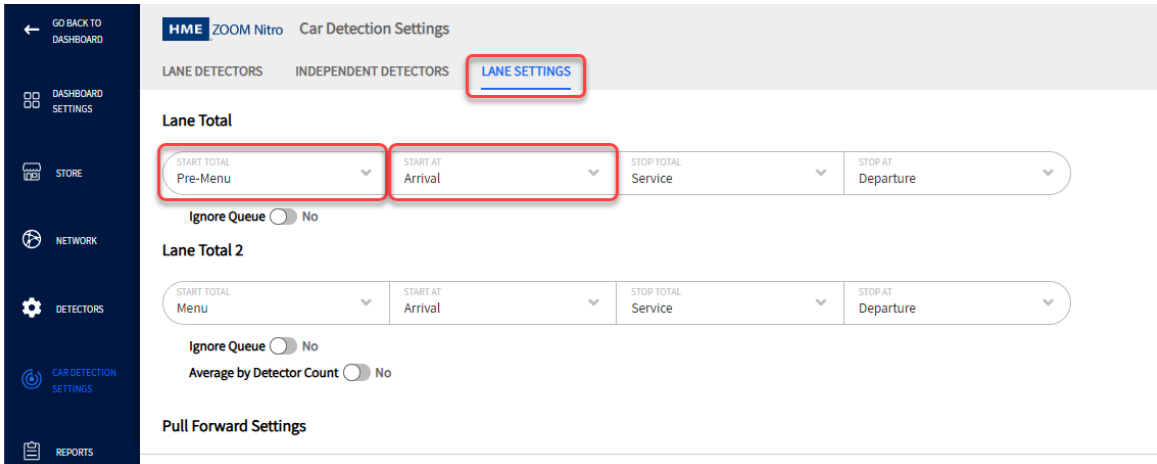

Fig. 38

- Go to DASHBOARD SETTINGS
There are additional options to display on the dashboard. Toggle the switches to enable or disable. Fig. 39 shows Drive Offs enabled, the Footer Drive Off Counter enabled, Pre-Menu Stack, and Use Menu Stack enabled.

Use Menu Stack is enabled by default; it combines Pre-Menu Stack and Pre-Menu into a single label called Menu Stack (see Fig. 40). This toggle is tied to the Pre-Menu Stack toggle above it, so if you disable Pre-Menu Stack, the Menu Stack (if enabled) is also disabled. If you enable Use Menu Stack, it will also enable the Pre-Menu Stack (if disabled). Toggle the Use Menu Stack switch to disable if you would prefer to see both Pre-Menu Stack and Pre-Menu labels displayed separately on the dashboard, as shown in Fig. 41 (the Pre-Menu Stack toggle must be enabled).

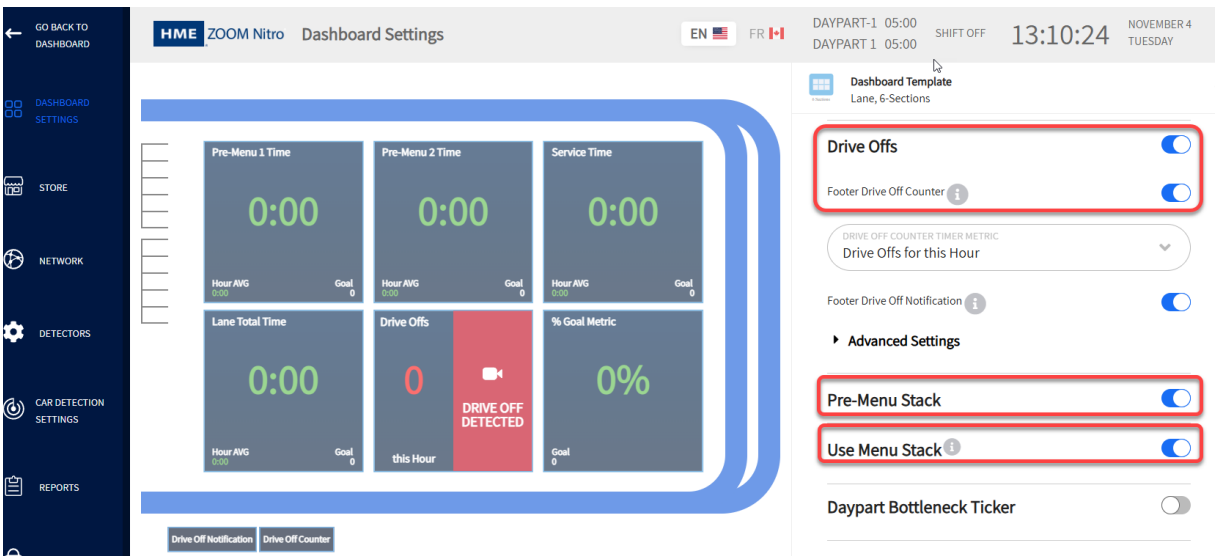

Fig. 39

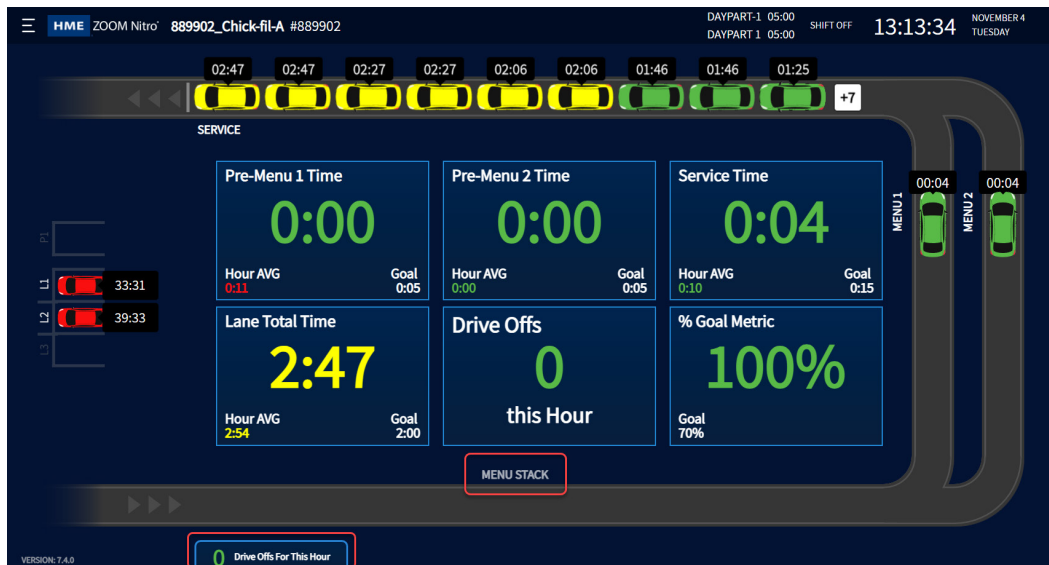

Fig. 40

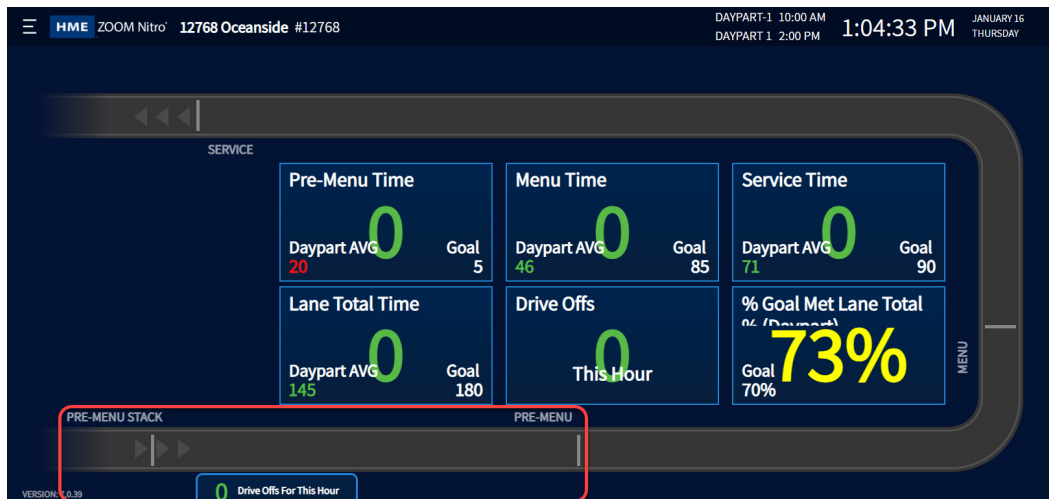

Fig. 41

COMPLETING THE INSTALLATION

1. Complete the final testing with the HME Support contact.
2. Complete Site cleanup.
3. Complete all paperwork.

PHOTO EXAMPLES OF CAMERA VIEWS WHEN CONFIGURED

The following images show examples of camera views in Drive-Thru Lanes and Mobile Spaces.

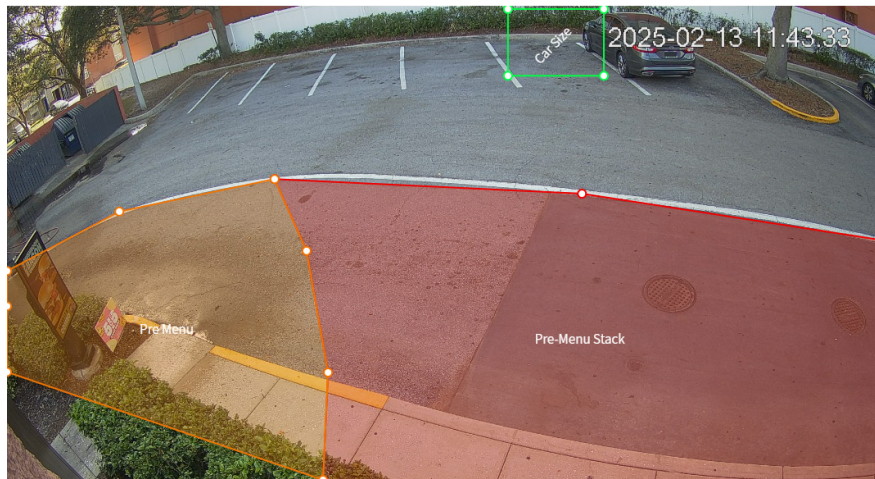

Single Lane Drive-Thru Example 1

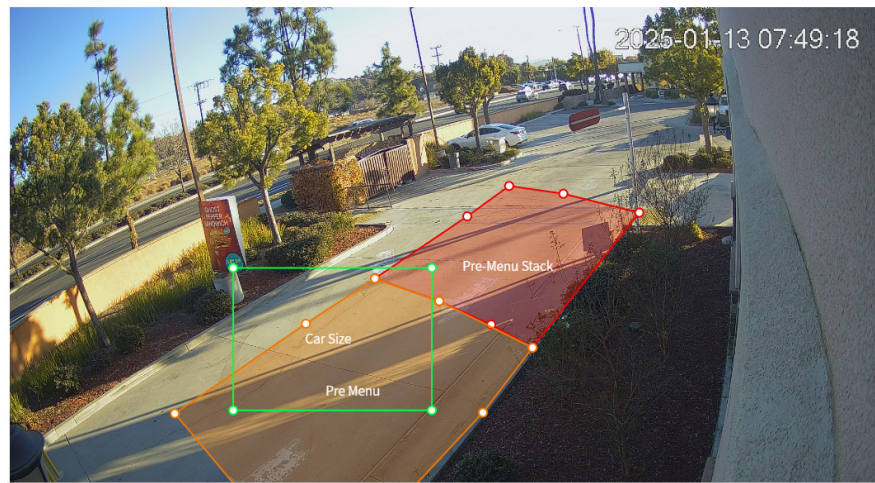

Single Lane Drive-Thru Example 2



Single Lane Drive-Thru Example 3



Single Lane Drive-Thru Example 4



Y Lane Drive-Thru Example 1



Y Lane Drive-Thru Example 2



Mobile Example 1

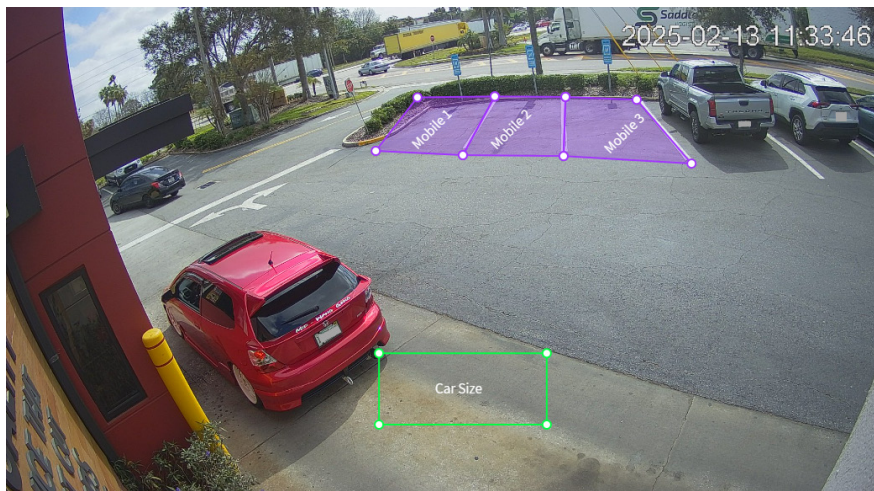

Mobile Example 2

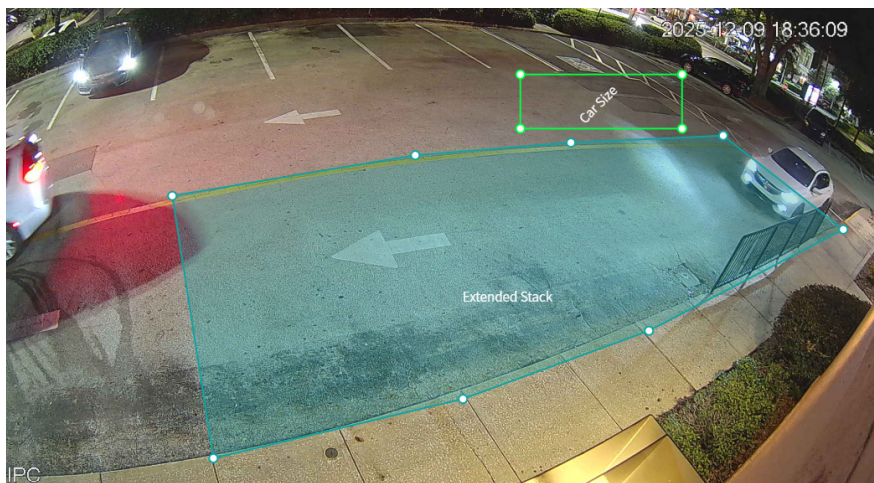

Extended Stack Example 1 (also see next image for lane continuance)

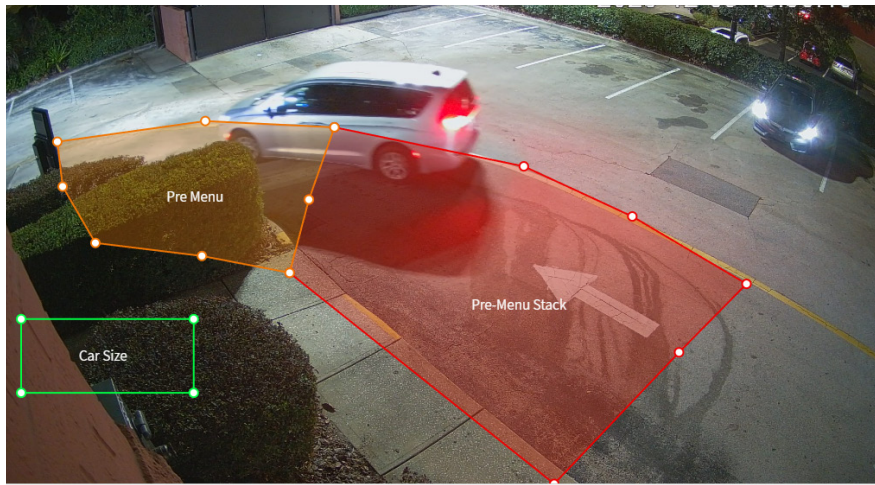

Pre-Menu/Pre-Menu Stack camera associated with the Extended Stack Example 1 camera

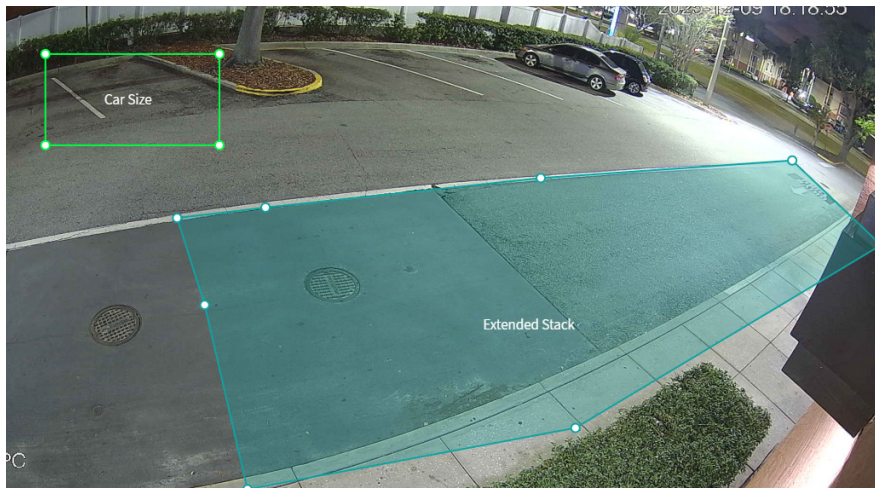

Extended Stack Example 2 (also see next image for lane continuance)



Pre-Menu/Pre-Menu Stack camera associated with the Extended Stack Example 2 camera

HELP AND TROUBLESHOOTING

TROUBLESHOOTING

For unresolved issues or those not covered in this section, please call HME Technical Support at: 800 848 4468

Problem	Solution
If using manual configuration (see next section under Manual Configuration) - Cameras not showing in Amcrest Config tool, or web browser (Camera Not Configured yet).	<ol style="list-style-type: none">1. Check Physical Connections, at the PoE switch, both port lights should be on.<ul style="list-style-type: none">o Check to make sure the camera is connected to a POE port (1-4) on the switcho The left light should be green or yellow, depending on network speed, and flashing if transmitting/receiving datao The right light will be on when providing PoE power, It will be flashing if there is a PoE issue.2. If the lights are not on, then test the cable<ul style="list-style-type: none">o If the cable passes, connect the cable, power cycle the switch, and try step 1 again.o If the cable fails, check the ends and re-terminate and retest.o If the cable is passing, but the Lights on switch are not on<ul style="list-style-type: none">• Try a different port on the switch• If available, use an IP Camera Test Monitor to verify camera is good (this tool can be used to power and view the camera)3. If Connection Lights are on<ul style="list-style-type: none">o Check the settings of the Amcrest IP Config tool, the start IP should be set to 192.168.1.1o Refresh the Amcrest IP toolo If still not showing Check IP address setup of the laptop: For Non-Configured Cameras, the IP Setting should be set to<ul style="list-style-type: none">• IP 192.168.1.200• Sub net 255.255.255.0• Gateway 192.168.1.1• DNS 8.8.8.8For Configured Cameras, the IP Settings should be set to<ul style="list-style-type: none">• IP 10.13.37.200• Sub net 255.255.255.0• Gateway 10.13.37.1• DNS 8.8.8.8
Camera View not showing in Amcrest tool or Web browser (Camera configured)	See above solution

Problem	Solution
VPU is not online	<ul style="list-style-type: none"> • Verify VPU has power and is turned on. • Verify VPU is connected to the correct port on the store switch specified in the work order • Verify the link lights are on at the VPU, and the store switch • Test the cable • Move the cable to different available ports (if assigned by the store's IT personnel) • Check that the VPU IP address is correct, call HME Technical Support
ZOOM Nitro is not online	<p data-bbox="630 562 915 588">Login to the Zoom Nitro</p> <ul style="list-style-type: none"> • Select the Network option and under the Local Network tab: <ul style="list-style-type: none"> o Verify the Control Unit Network is "Connected" o Verify the IP information is correct • Go to the HME CLOUD tab <ul style="list-style-type: none"> o Verify that it is ON o Verify the account email is correct o Verify the Account Status is registered o Run Test Connection <ul style="list-style-type: none"> • If it passes, reboot the CU and try again • If it fails, test cable and/or move the cable to different available ports (if assigned by the store's IT personnel)
Equipment will not power on	<ul style="list-style-type: none"> • Check Connections at equipment and outlet • Test the outlet using an electrical outlet tester <ul style="list-style-type: none"> o If the outlet passes, re-seat the cables and retry o If the outlet fails, move to a functional outlet
Cameras not showing on ZOOM Dashboard	<ul style="list-style-type: none"> • Verify Cameras are live from laptop <ul style="list-style-type: none"> o If No, see "Cameras not showing..." problem o If yes, continue • Verify Zoom Nitro is Online and connected to the HME CLOUD <ul style="list-style-type: none"> o If No, see "ZOOM Nitro not online" problem o If yes, continue • Verify VPU is Online <ul style="list-style-type: none"> o If No, see "VPU not online" problem o If Yes, continue • Verify Nitro Vision AI is enabled and shows "connected." If Not: <ul style="list-style-type: none"> o Toggle the setting to disable. Wait 30 seconds, then toggle the setting to enable again o Click on "Refresh All Cameras"
Nitro Vision AI not working to show car movement	<ul style="list-style-type: none"> • Call HME Technical Support

Problem

Solution

DETECTORS>CAMERA tab

Error prompt: You do not have access to Nitro Vision AI. Please reach out to your HME Sales contact for more information.

1. Go to NETWORK>HME CLOUD tab.

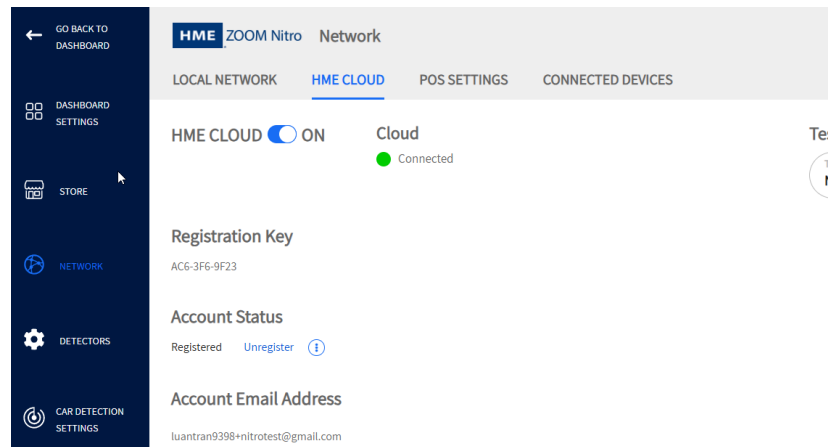

2. Take a photo or write down the Registration Key and Account Email Address.
3. Under Account Status, click/tap “Unregister.”
4. When the page refreshes, Click/tap the blue text “I have a registration key.”

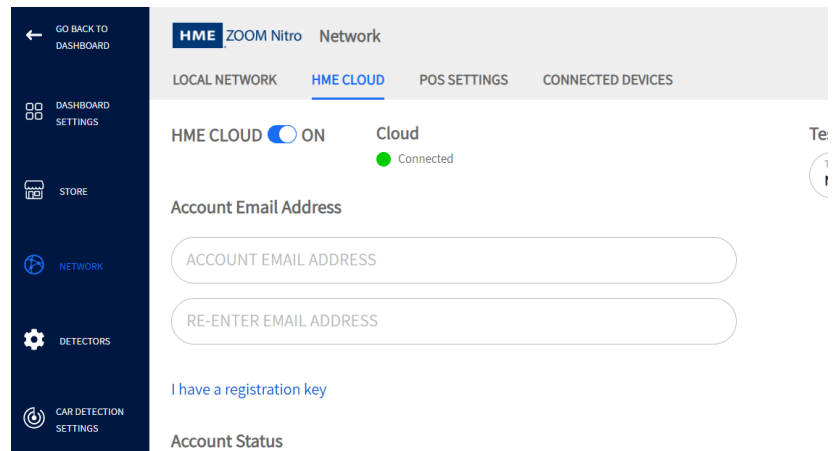

5. Enter the registration key (letters are case sensitive), then click/tap the “enter” key on the pop-up keyboard.
6. Click/tap the blue “Register” button.
7. Click/tap “Yes, Continue” when the dialog prompt appears confirming store found.
8. Power cycle the VPU to reboot.

Problem	Solution
Cable did not pass the test	<p>If you have the ability to terminate Cat 6 Cable</p> <ul style="list-style-type: none"> • Visually inspect both RJ45 ends for incorrect wiring or debris preventing electrical contact. <ul style="list-style-type: none"> o If debris, clean contacts and retry o If wiring is incorrect, cut, replace, and terminate new RJ45. <p>If you don't have the ability to terminate Cat 6 Cable.</p> <ul style="list-style-type: none"> • Call HME for new cable. • Replace cable if you have an extra one (strain relief on RJ45 cannot be molded when used with waterproof coupler)
Physical obstacle preventing access to camera location (indoor or outdoor) or Physical obstructions to camera View (e.g., Trees, extended cooler, etc.)	<ul style="list-style-type: none"> • Can the obstacles or obstructions be moved, or can another camera mounting location be used? <ul style="list-style-type: none"> o Take Photos of Obstructions from multiple angles o Take Photos of proposed new location you can access <p>Forward to HME to get direction on resolution</p>
Missing Parts in Shipment	Contact HME: 1 800 848 4468

NETWORK REQUIREMENTS

This information is available in a document called "HME Devices Network & Systems Requirements," which can be found online in the "Supporting Documents Library" on the HME website under Training. Or click on <https://www.hme.com/training/supportingdocuments/?lng=1>

MANUAL CONFIGURATION USING COMPUTER AND CAMERA

If the pre-configured camera cannot be installed or accessed via the standard procedure, it may need to be manually configured and adjusted. To view the camera feed on a computer, the Amcrest IP Config Tool needs to be installed (covered in the next section). Your computer must also be configured. Note or take screenshots of your current settings so you can return to them after you have completed the installation. These instructions are based on a laptop running Windows 10.

1. Go to Windows>Settings and select Network & Internet.

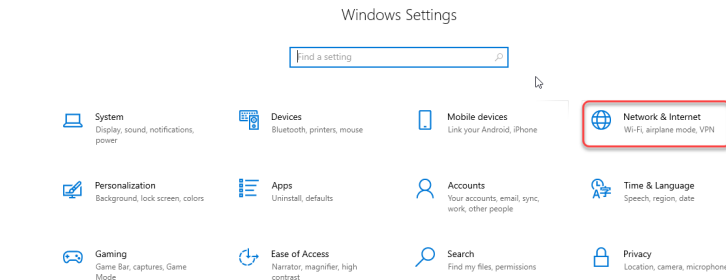

2. From the Status option, click/tap on Properties.

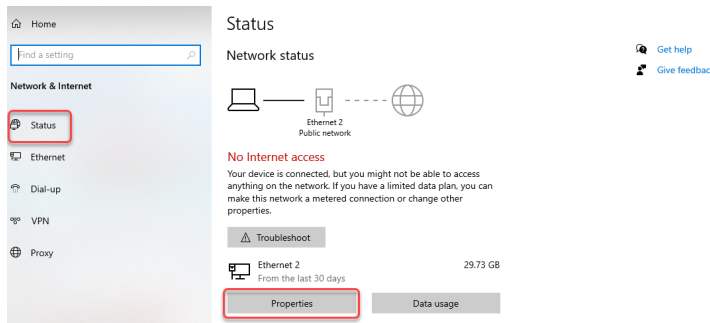

3. Under IP Settings, click/tap on Edit.

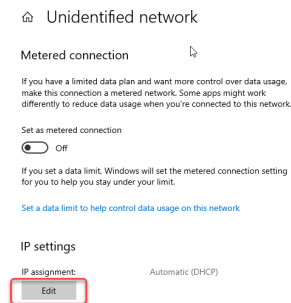

4. Select Manual from the drop-down list and save your selection.

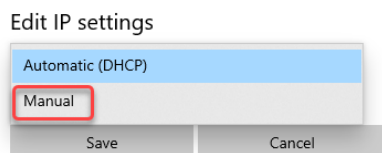

5. Under Edit IP Settings, toggle Pv4 On.

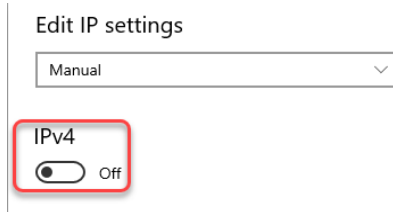

6. Populate the fields with the following information and save your selection.

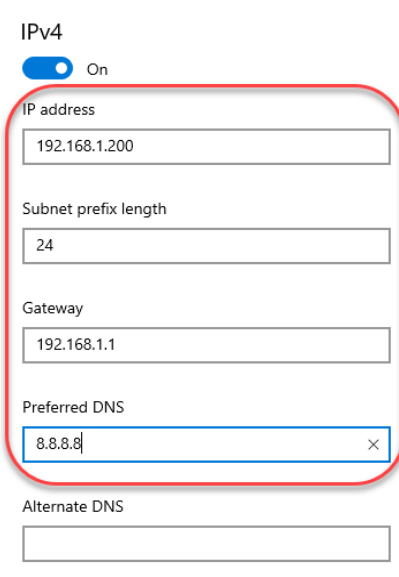

Windows 10

VERIFY THE CAMERA CONFIGURATION AND VIEW

The camera(s) may need to be configured when you receive them. To configure or verify settings:

- Download the Amcrest IP Config tool from the Amcrest website here: Choose the download link for your OS, Windows, or Mac (Windows is recommended and used in the following instructions). <https://support.amcrest.com/hc/en-us/articles/360004527171-Amcrest-IP-Config-Tool-Download>
- The camera is connected to the PoE switch (ports 1 - 4). PoE switch port 5 connects to your laptop computer.

The Amcrest IP Config tool

When you open the Amcrest IP Config tool, you see a screen like this. One or more cameras will be listed depending on the sales order. If they are not showing, click/tap on the “Refresh” button.

To log in to the camera, click/tap on the  icon in the Operate column on the far right.

This takes you to the Amcrest IP Camera Web Access Login page. See the Camera Configuration section.



Fig. 2.1

Camera Configuration

1. Log in to the Camera portal using these credentials: For Username and Password, enter the word “admin” into both fields. Then click/tap the Login button. See Fig. 2.2.

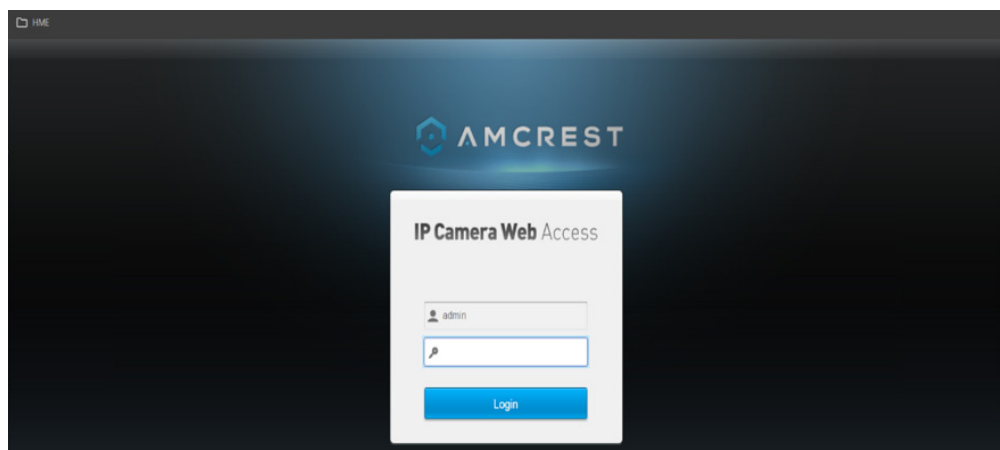

Fig. 2.2

2. You are then prompted to create a new password. Enter the word (with exclamation point) "evdHME2020!" as the new password, confirm password, and click/tap Ok.

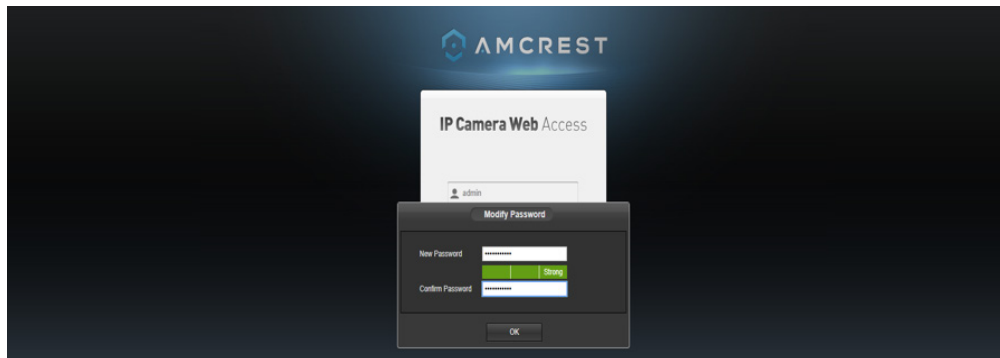

Fig. 2.3

3. With the configuration now set and a live view displayed (Fig. 2.4), you may need to adjust the camera to get the best, unobstructed view of the target location.
 - Loosen the security screw with the Torx wrench that came with the camera (see Fig. 10).
 - Adjust the camera angle as necessary.
 - Tighten the security screw to secure it.
 - You will also need to confirm the adjusted position with the HME team at the end of this procedure.

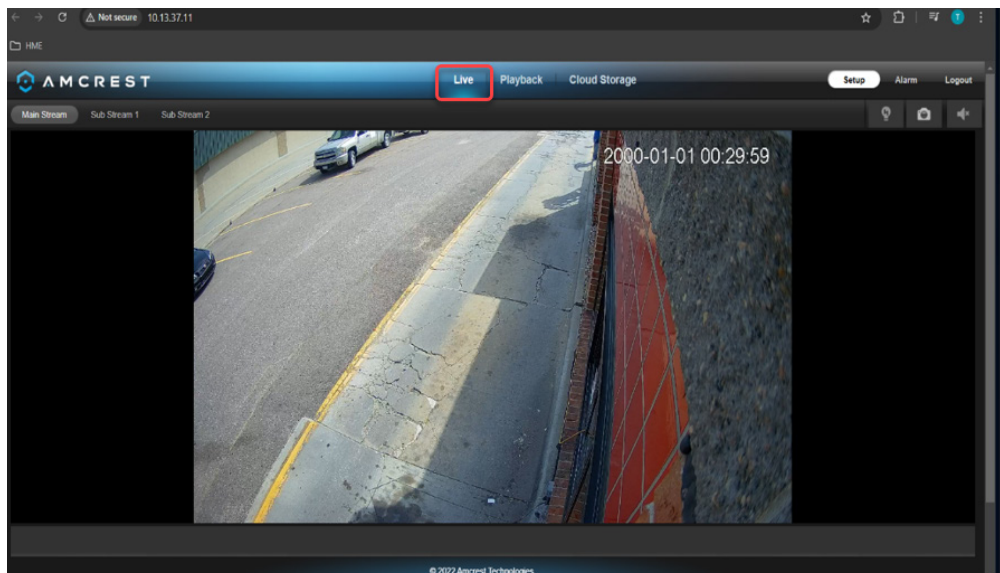

Fig. 2.4

4. Go to Setup.

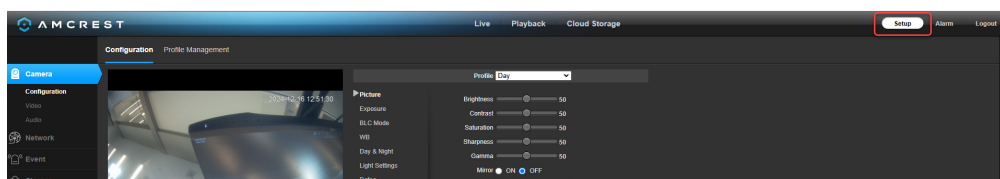

Fig. 2.5

5. Go to Camera>Video. Under the Main Stream section (Fig. 2.6), modify/verify the following fields:

- Encode Mode: H.264
- Smart Codec: OFF
- Resolution: 1920*1080(1080p)
- Frame Rate(FPS): 20
- Bill Rate Type: CBR
- Bill Rate: Customized

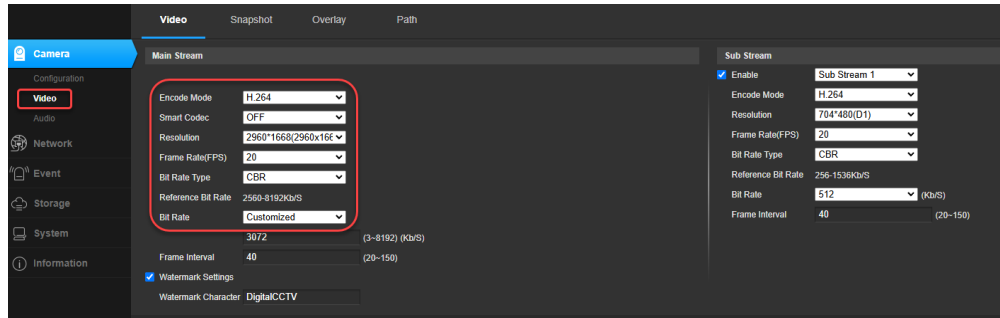

Fig. 2.6

6. Go to Camera>Overlay (Fig. 2.7). Ensure that no Overlay data obscures the camera view. Move or Disable the Channel Title or Time as necessary. Save settings if modified.

- Checking Disable on an overlay feature makes it disappear from the camera feed. For example, the Channel Title is “Disabled” in Fig. 2.7, so it is no longer visible in Fig. 2.8 once saved.
- To reposition the Time, leave the Overlay feature “Enabled” grab the onscreen Time, and drag it to a new location on the camera feed. For example, Time is still “Enabled” in Fig. 2.8 but was moved from its original location in the upper right corner of Fig. 2.7 to the lower left in Fig. 2.8.

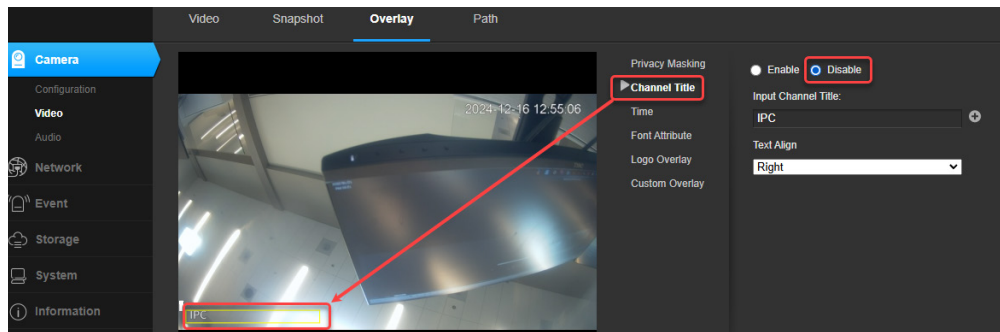

Fig. 2.7

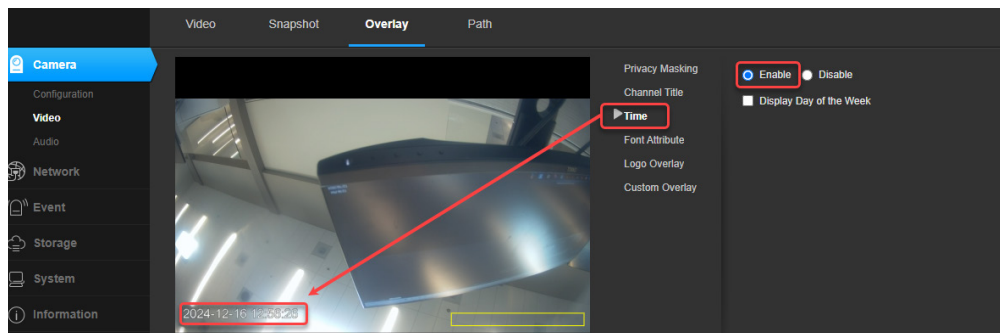

Fig. 2.8

7. Go to System>General>Date/Time (Fig. 2.9). Date and Time may need to be configured.
 - Check the Enable DST box (1) if applicable for your location.
 - Check the Sync with NTP Server box (2).
 - Click/Tap on the PC Sync button (3).
 - Save your selection (4).
 - When the prompt appears, click/tap OK (5).

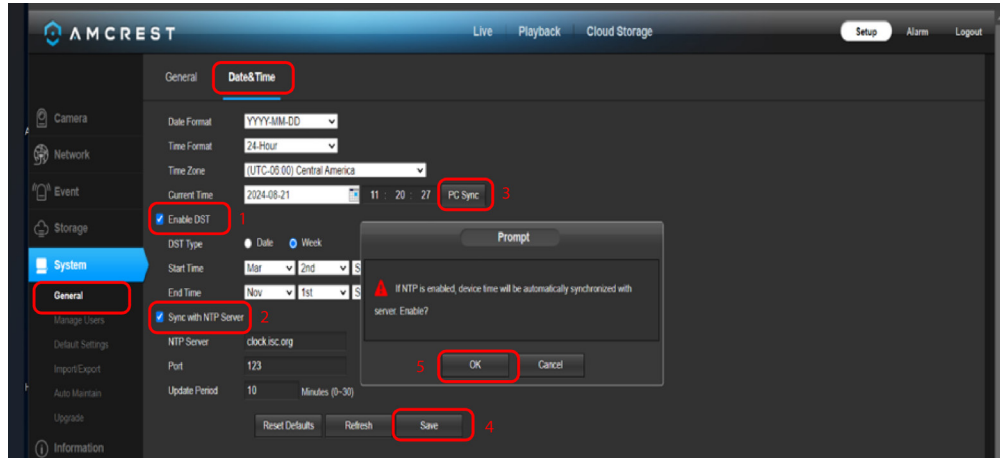

Fig. 2.9

8. Go to Network>TCP/IP (Fig. 2.10). Configure with the following settings.

NOTE: Enter all required information listed below **first** before saving (as this will disconnect the camera).

- Mode: Enable Static
- IP Address (for 1st Camera): 10.13.37.10
- IP Address (for 2nd Camera if applicable): 10.13.37.11
- Subnet Mask: 255.255.255.0
- Default Gateway: 10.13.37.1
- DNS: Leave at Default

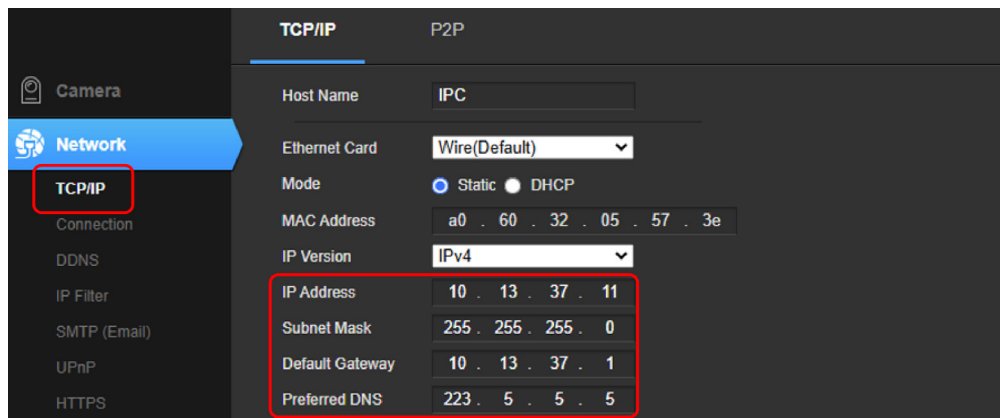

Fig. 2.10

9. Disconnect the PC/laptop from the PoE Switch and plug the VPU back into port 5 of the PoE Switch.
10. Call HME Support at: 800-848-4468 to confirm the camera view is correctly positioned. They will

connect to the live camera feed remotely, and if an adjustment is needed, repeat step 3. Since you are adjusting the camera angle without the ability to see the camera view, remain on the phone. The HME team will be your eyes and direct the adjustment as needed until it is correctly positioned.

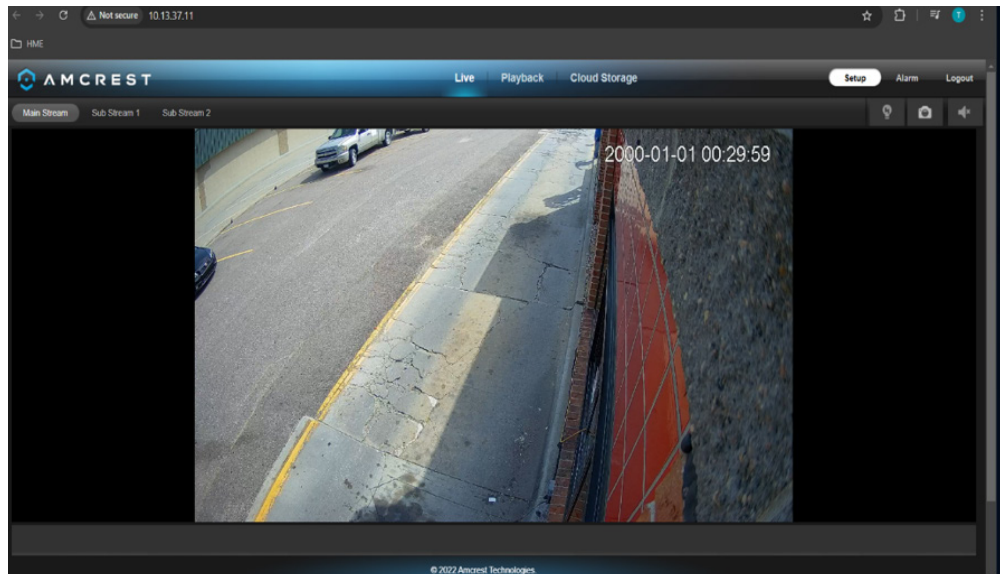

Fig. 2.11

Factory Reset

This menu option is found under “System>Default Settings.” This screen allows the user to reset the camera and all its settings to the factory settings. Below is an explanation of the items listed in this field:

- Default Settings: Only the IP address, user management, and other settings can be recovered after reset.
- Factory Default: Completely resets the camera to factory default settings. No settings can be recovered after the camera has been returned to its factory default settings.

To perform a physical factory reset to this camera, make sure the device is powered on and follow the instructions provided below.

1. Locate the Reset hatch on the top of the camera. Using a Phillips head screwdriver, remove the 2 security screws to open the hatch (Fig. 2.12).
2. Press and hold the Reset button for 30 - 45 seconds, to allow the camera to reset (Fig. 2.13).
3. Once the camera reset is complete, place the reset hatch back onto the camera and secure it with a Phillips-head screwdriver and security screws (Fig. 2.12).

The camera has now been factory reset and reverted to its original factory settings. This includes usernames, passwords, and other settings. The default username and password are admin.



Fig. 2.12

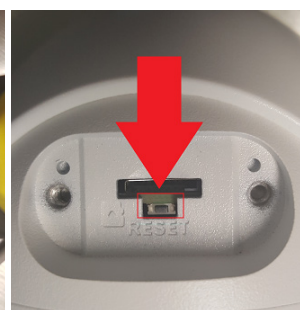

Fig. 2.13

GLOSSARY OF TERMS

CU: Control Unit/CU60, Part of the Timer system used with a Timer/TSP. It receives and processes lane event data from the TSP and then outputs this data for display in a visual format on the system monitor.

Detector: A component of the Timer system. A sensor used to sense or capture the presence of a vehicle. These can be wire loops or cameras, or a combination of both.

DHCP: Dynamic Host Configuration Protocol is a network management protocol used on UDP/IP networks. A DHCP server dynamically assigns an IP address and other configuration parameters to each device on a network so they can communicate with other IP networks.

DNS Server: Domain Name System Server is a directory of domain names with translated IP addresses.

Drive Off: This is when a vehicle is in line to order (pre-menu) but then decides to leave or drive off before placing an order. This can be due to long wait times or a change of mind.

Gateway: A device (usually a router) that connects a computer(s) on a network to other networks or the Internet.

HME CLOUD: This is a remote server used by your system. It allows your system to access and store data via the Internet. It also provides access to other systems in your network connected to the HME CLOUD.

IP Address: Internet Protocol Address. A unique computer address that some electronic devices (such as computers or routers) use to identify and communicate with each other on a network.

MAC Address: Is a unique identifier assigned to a network interface controller (NIC) for use as a network address in communications within a network segment.

Menu Stack: This is a default cosmetic dashboard label. It combines both the pre-menu and pre-menu stack zone labels into a single label to simplify what is displayed on the monitor dashboard.

NTP: Network Time Protocol is a networking protocol for clock synchronization between computer systems and is intended to synchronize all participating systems to within a few milliseconds of local standard time or Coordinated Universal Time (UTC)

Nitro Vision AI: Is a vehicle detection method which utilizes cameras and proprietary AI firmware to identify and track vehicles in a drive-thru lane environment or parking spaces designated for pick-up. Also see Zones.

Nitro Vision AI Accuracy Metrics: A definition of terms used in Video Detection metrics

- **Good Tracks:** Vehicle ID'd and tracked through entire Pre-Menu zone
- **Undetected:** Vehicle not detected in Pre-Menu zone
- **ID Transfer:** Vehicle assigned an ID, but ID is transferred to another vehicle due to an occlusion
- **ID Loss:** Vehicle assigned an ID which is lost
- **Occlusion Related:** Error related to an item blocking the camera view of the vehicle
- **False Positives:** System detects a vehicle when one is not present

PoE: Power over Ethernet describes several standards that allows a single cable (twisted pair Ethernet cabling) to provide both data connection and electric power to devices such as Wireless Access Points, IP cameras, and Voice over IP phones, etc.

QSR: Quick Service Restaurant, is a restaurant specializing in the quick preparation and service of food, which generally includes the use of an external ordering system in a drive-thru lane environment.

Subnet Mask: Splits the network into a series of subgroups or subnets to speed up the delivery of data by the routers.

TSP: Timer Signal Processor. Part of the Timer system used to receive and sort data from peripheral detectors. It forwards this data to the CU for processing.

VPU: Video Processing Unit, this device processes video data input from the camera(s) intended for output to a display device.

Web Server Port: This is the unique network port number used by NEXEO to communicate over the network it is connected to.

Whitelist - The practice of explicitly allowing some identified entities access to a particular privilege. For Local Area Networks, this is to control who and what is allowed on a protected network. In this case, it permits hardware to access necessary ports and URLs over a store's secure network.

Zones - These are specific areas of a drive-thru environment or parking spaces designated for pick-up that are targeted by Vision AI and defined on the VPU Setup page. Zones include:

- **Mobile Space:** A designated parking space/area assigned by the store outside of the drive-thru lane (independent detectors). These can be parking spaces reserved for mobile order pickups.
- **Extended Stack:** This is an extended area behind the pre-menu stack where customers drive through before reaching the Pre-Menu/Pre-Menu Stack zones.
- **Pre-Menu Stack:** This is an area behind the pre-menu where customers can potentially exit the lane and drive off if they decide not to wait.
- **Pre-Menu:** This is the area where a single car is waiting just before reaching the order point.
- **Pull-Forward:** This is a space off the drive-thru lane where vehicles await their orders, thus alleviating lane congestion.

POE SWITCH TEMPLATE FOR WALL MOUNTING

When this page of the PDF is printed (to **actual size**), this template can help with the hardware placement.

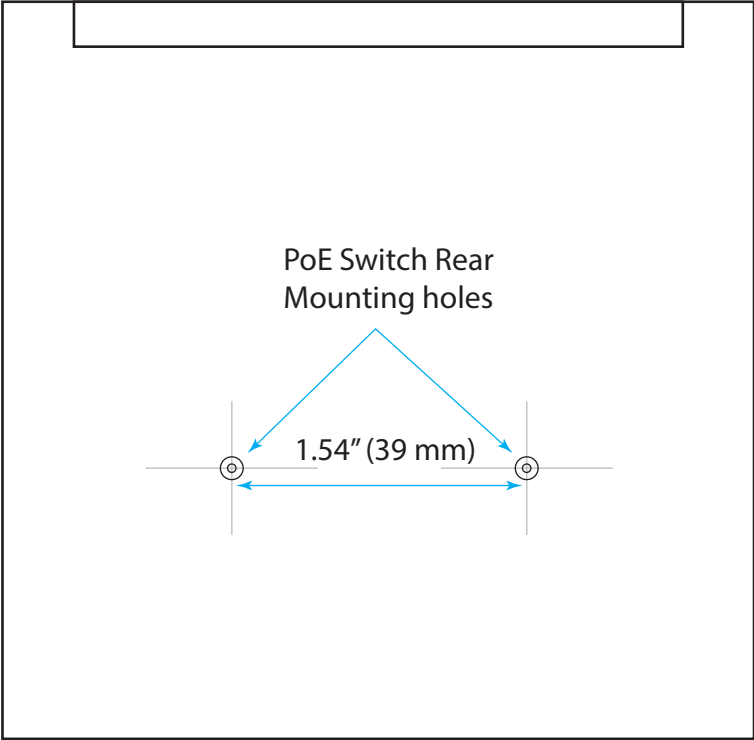



A copy of this guide and much more can be found under ZOOM Nitro by scanning this QR code or going to:
<https://www.hme.com/qsr/drive-thru-user-manuals/>